

lync[®]



OPERATIVE TECHNIQUE

FOREFOOT

PIP & DIP intramedullary implants



- . **Mechanical expansion** - Pure titanium
- . **Immediate intraoperative anchorage**
- . **Rotation resistant** - migration resistant
- . **Straight or 10° anatomical offset**

*Creating
Better
Together™*



Introduction

. Indications	03
. Contra-indications	03
. The Lync® Solution	04

Surgical Technique

. Proximal Inter-phalangeal Arthrodesis :	
1 - Approach	05
2 - Preparation of the Proximal Phalanx (P1)	05
3 - Preparation of the Distal Phalanx (P2)	06
4 - Implant Insertion	07
5 - Implant Impaction	08
. Distal Inter-phalangeal Arthrodesis :	
1 - Approach	09
2 - Preparation of the Distal Phalanx (P3)	09
3 - Preparation of the Middle Phalanx (P2)	10
4 - Implant Insertion	11
5 - Implant Impaction	12

References

. Lync and Instrumentation	13
----------------------------------	----

Introduction

Indications

Intramedullary implants are indicated for arthritis and bone alignment defaults (hammertoe, claw toe, mallet toe, claw hand and mallet finger) in fingers and toes.

Contra-indications

- . Bone destruction or poor bone quality, likely to impair implant stability.
- . Hypersensitivity to titanium.

Note: Detailed information on each medical device is provided in the instruction for use. Refer to the instruction for use for a complete list of side effects, warnings, precautions for use and directions for use.



Introduction

The Lync® Solution

Its anti rotation design reduces the risks of rotation and pullout. Its expansion capacity and the notched grooves allow effective intraoperative anchorage to prevent migration.

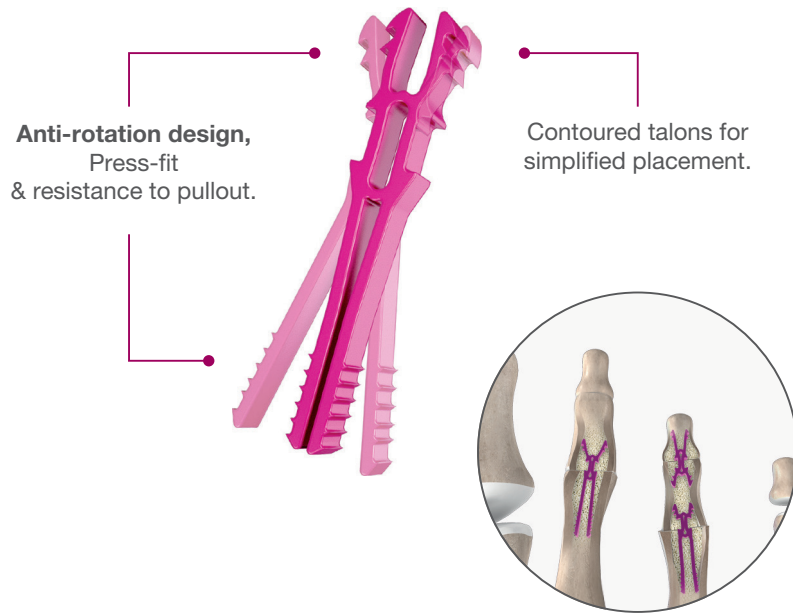

Features

Initial anchorage by means of mechanical expansion of the implant.

Interphalangeal gap reduction by compression, anchorage due to press-fit fixation.

Mechanical resistance to pullout and rotation.

No freezing. The implant may be used at ambient temperature.

Anodized pure titanium (Nickel free) - Radiopaque.

The Range

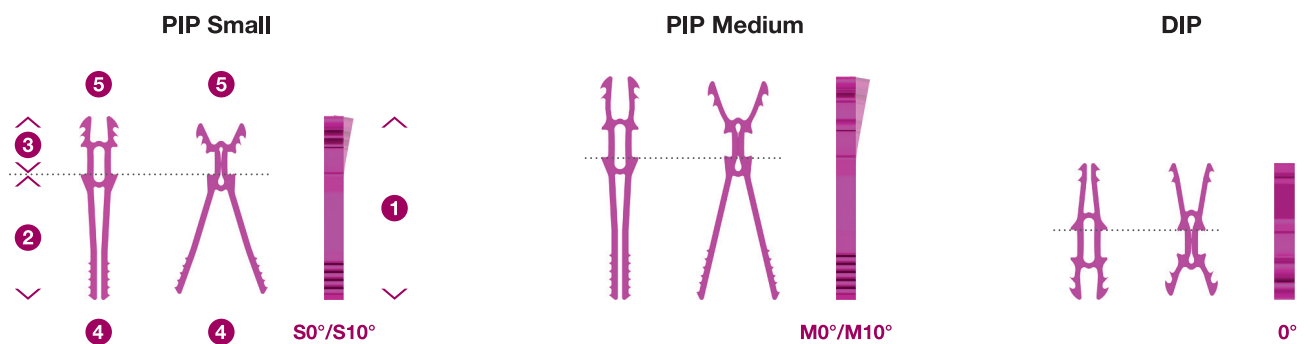

	Small	Medium	DIP
1 - Total Length	16 mm	20 mm	12 mm
2 - Proximal Length	11 mm	13 mm	6 mm
3 - Distal Length	5 mm	7 mm	6 mm
4 - Initial / Final Proximal Opening*	2 / 8 mm	2 / 8.5 mm	3.5 / 4.0 mm
5 - Initial / Final Distal Opening*	3.5 / 5.5 mm	3.5 / 4.5 mm	2 / 5 mm

* Maximum Opening.

Surgical Technique

This document provides technical guidance for the proper usage of the Lync® Hammertoe implant, however Novastep does not recommend this or any other surgical technique.

Proximal Inter-phalangeal Arthrodesis

1 - Approach

Make a transverse incision to expose the joint. The extensor is cut transversely, leaving a distal central strip free. Dorsal arthrolysis is performed by cutting the internal and external ligaments. A plantar flexor tenolysis procedure may also be utilized.

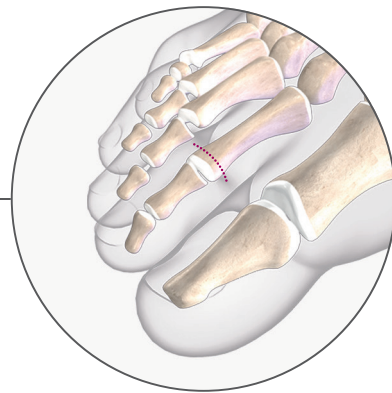

2 - Preparation of the Proximal Phalanx (P1)

2.1 - Resect the proximal phalangeal head with an oscillating saw (about 2-3 mm).

The plantar plate and the lateral ligaments may be released with a periosteal elevator or with a cutter to facilitate joint distraction.

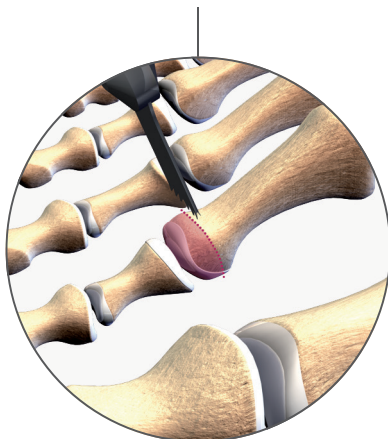

2.2 - Prepare the proximal phalangeal canal using the drill bit. Drill until the cutting flutes are buried into the bone fragment.

Note: In case of narrow canal, the drill bit may be used in a reciprocating fashion to widen the pathway.

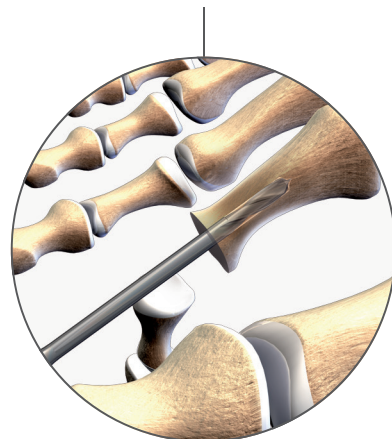

Surgical Technique

3 - Preparation of the Distal Phalanx (P2)

3.1 - Minimally resect the distal phalangeal head.

Optional: it is also possible to manually denude the cartilage using the provided Surfacing Reamer.

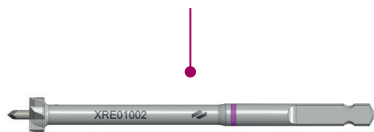
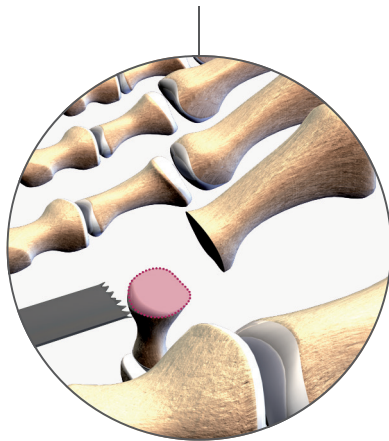

Surfacing Reamer

3.2 - Prepare the proximal phalangeal canal using the drill bit.

Note: In case of narrow canal, the drill bit may be used in a reciprocating fashion to widen the pathway.

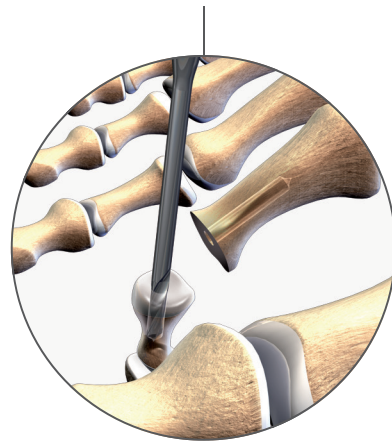

3.3 - Finalize the medullary canal preparation by making a reciprocating movement with the rasp until the rasp shoulder is flush with the plane of the resected bony surface.

Note : To avoid creating an oversized medullary canal, do not use the rasp in the proximal phalanx.

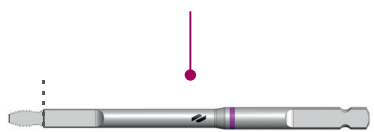
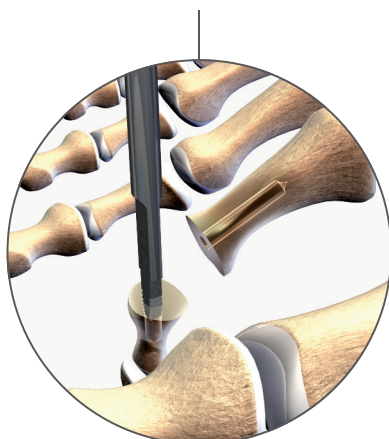

Shoulder

Rasp

3.4 - Check to ensure proper joint surface contact.

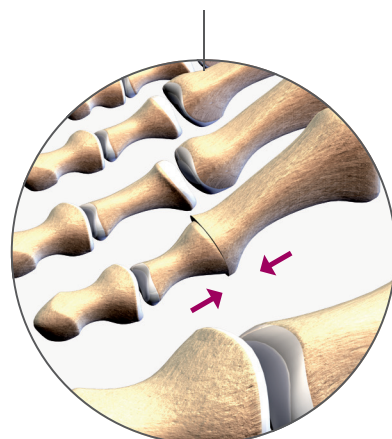

Surgical Technique

4 - Implant Insertion

4.1 - Capture the implant by positioning the tip of the forceps on the oval flats of the Lync® and ensure that the implant is situated at 90° with respect to the instrument in all planes.



Press on the forceps handles until you hear a click to lock the implant in place.

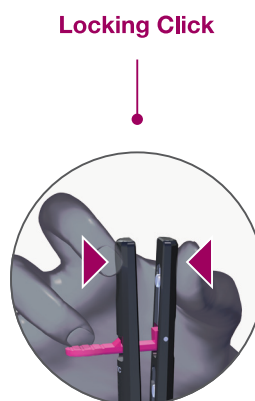

4.2 - Insert the implant into the proximal phalanx until the forceps touch the bony surface. Do not remove the forceps at this stage of the insertion.

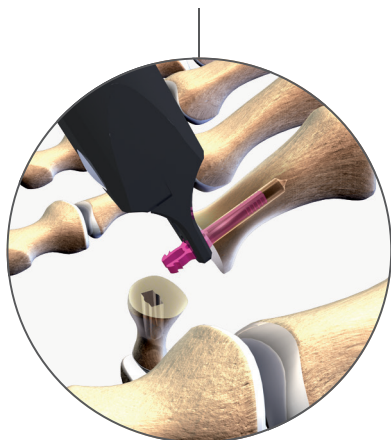

4.3 - Slide the distal phalanx back on to the distal implant legs. Maintain the forceps in position.

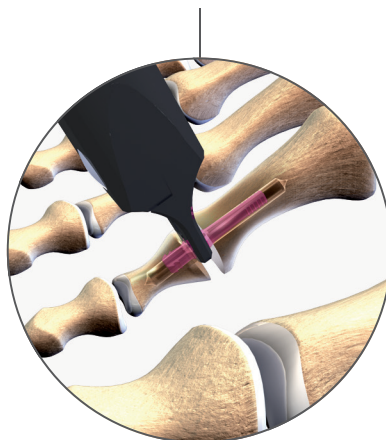

Surgical Technique

4.4 - To ensure proper anchorage, spread the proximal and distal legs of the implant by depressing the pink forceps lever while simultaneously closing the forceps handles. The notched grooves on the implant legs will engage with the inner walls of the medullary canal to achieve stable primary fixation.

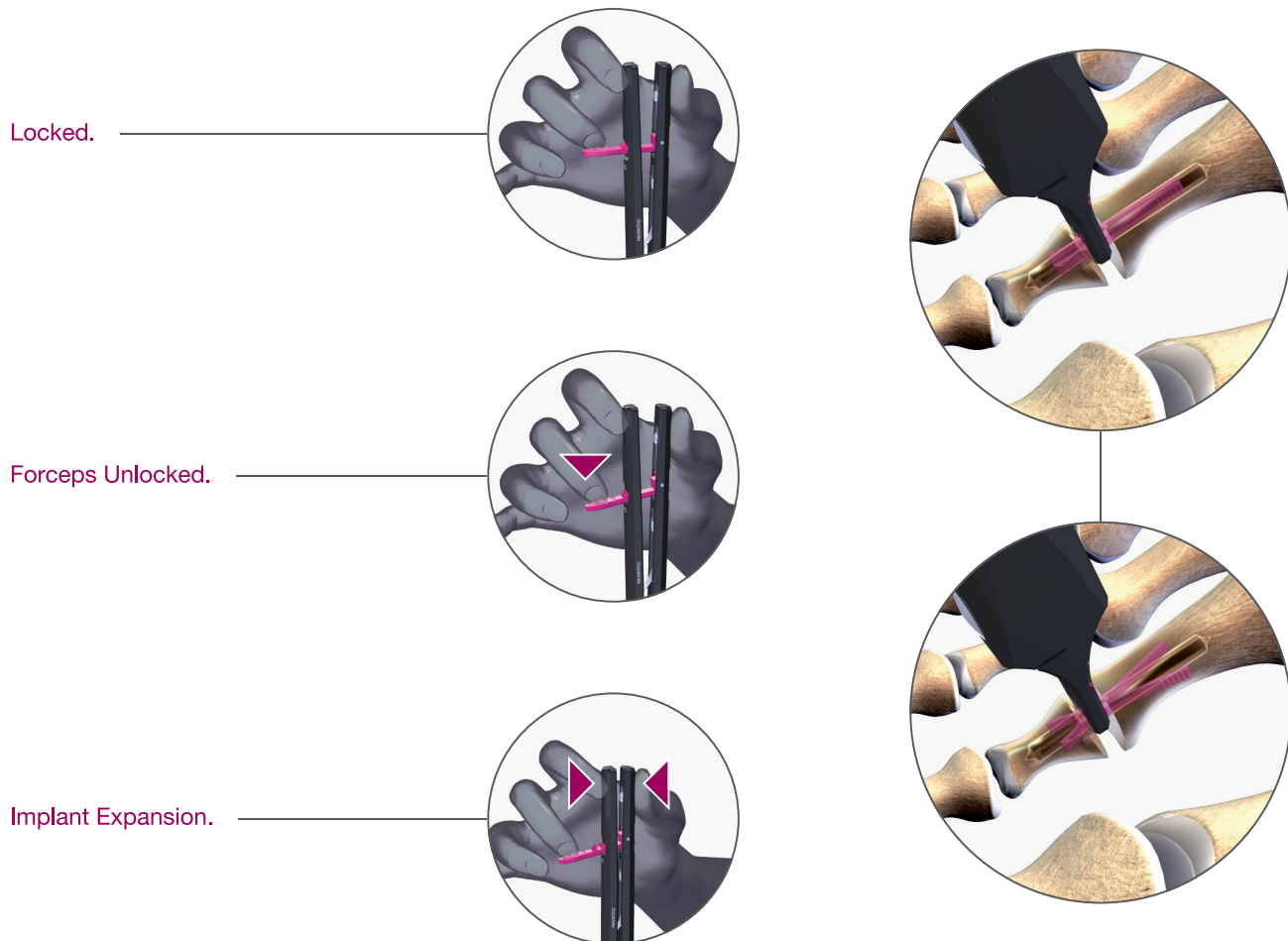

5 - Implant Impaction

Remove the forceps from the implant and manually compress the middle and proximal phalanges. The implant will now be fully anchored by press-fit in the intramedullary canal.

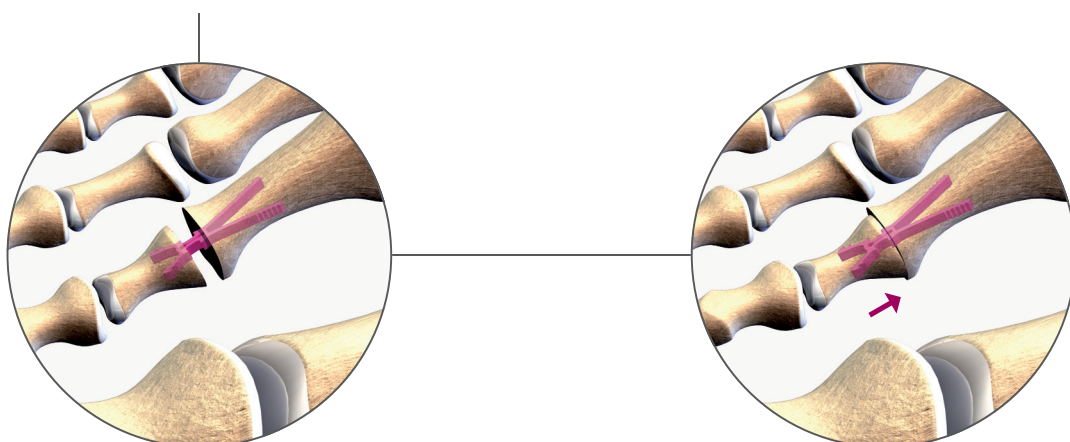

Surgical Technique

Distal Inter-phalangeal Arthrodesis

1 - Approach

Make a transverse incision to expose the joint. The extensor is cut transversely leaving a distal central strip free. Dorsal arthrolysis is performed by cutting the internal and external ligaments. A plantar flexor tenolysis procedure may also be utilized.

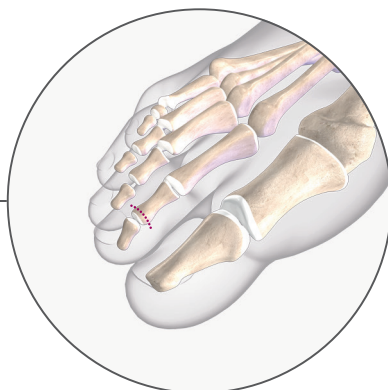

2 - Preparation of the Distal Phalanx (P3)

Resect the distal phalangeal head to reach the cancellous bone (about 1 mm). Prepare the distal phalangeal canal using the drill bit.

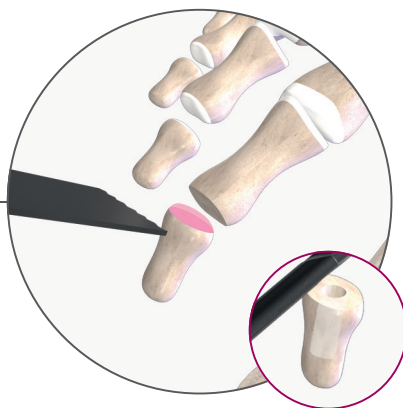

Note: Take care to keep as much bone as possible. In case of narrow canal, the drill bit may be used in a reciprocating fashion to widen the pathway.

Surgical Technique

3 - Preparation of the Middle Phalanx (P2)

Resect the middle phalangeal head with an oscillating saw (about 2 mm). Release of the plantar plate and the lateral ligaments facilitates joint distraction. Prepare the medullary canal for implant insertion by creating a pilot hole with the drill bit and then use the rasp to finalize the opening by pushing it through the canal, using a reciprocating movement, until the rasp shoulder is flush with the plane of the resected bony surface.

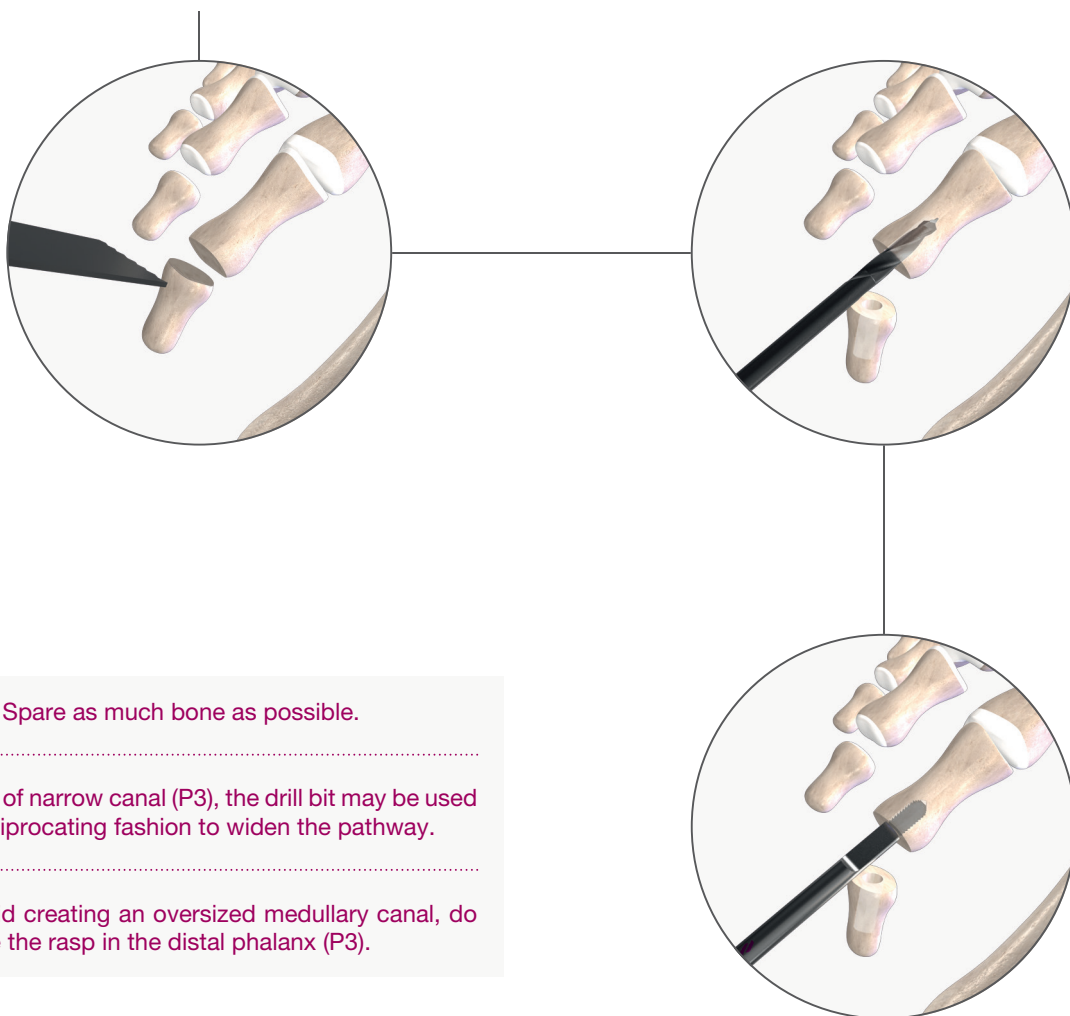

Notes: Spare as much bone as possible.

.....
In case of narrow canal (P3), the drill bit may be used in a reciprocating fashion to widen the pathway.
.....

To avoid creating an oversized medullary canal, do not use the rasp in the distal phalanx (P3).

Surgical Technique

4 - Implant Insertion

Grasp the implant using the Lync® forceps (*Steps specified under the Proximal Interphalangeal Arthrodesis heading - Section 4, Section 4.1*).

Note: Ensure that the implant is situated at 90° with respect to the instrument in all planes.

ATTENTION - Positioning of the Distal Interphalangeal Implant (DIP) is reversed in relation to the Proximal Interphalangeal Implant (PIP). Be sure to insert the narrower legs of the DIP implant on the distal side (P3) and the wider legs into the middle phalanx (P2).

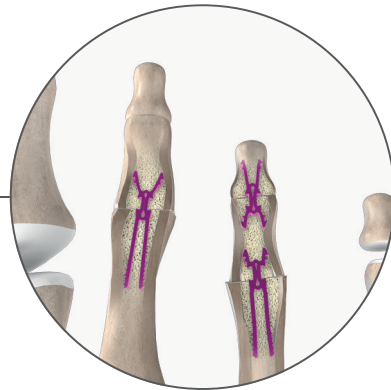

4.1 - Insert the implant into the distal phalanx (P3) until the forceps touch the bony surface. Do not remove the forceps at this stage of the insertion.

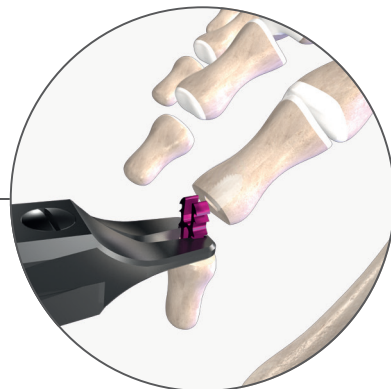

Surgical Technique

4.2 - Slide the medial phalanx (P2) back on to the shorter implant legs. Maintain the forceps in position.

To ensure proper anchorage, spread the proximal and distal legs of the implant by depressing the purple forceps lever while simultaneously closing the forceps handles (*Steps specified under the Proximal Interphalangeal Arthrodesis heading - section 4, paragraph 4.4*). The notched grooves on the implant legs will engage with the inner walls of the medullary canal to achieve reliable fixation.

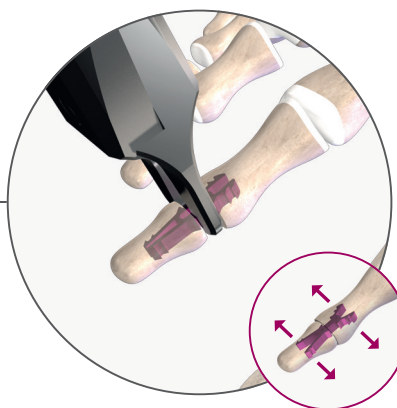

5 - Implant Impaction

Remove the forceps from the implant and manually compress the distal (P3) and the medial (P2) phalanges. The implant will now be fully anchored by press-fit in the intramedullary canal.

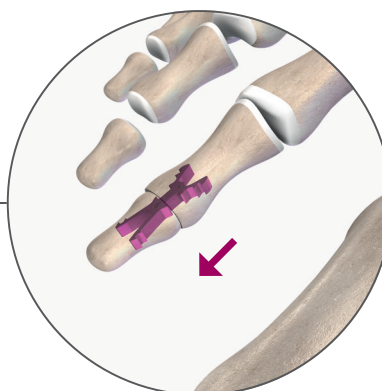



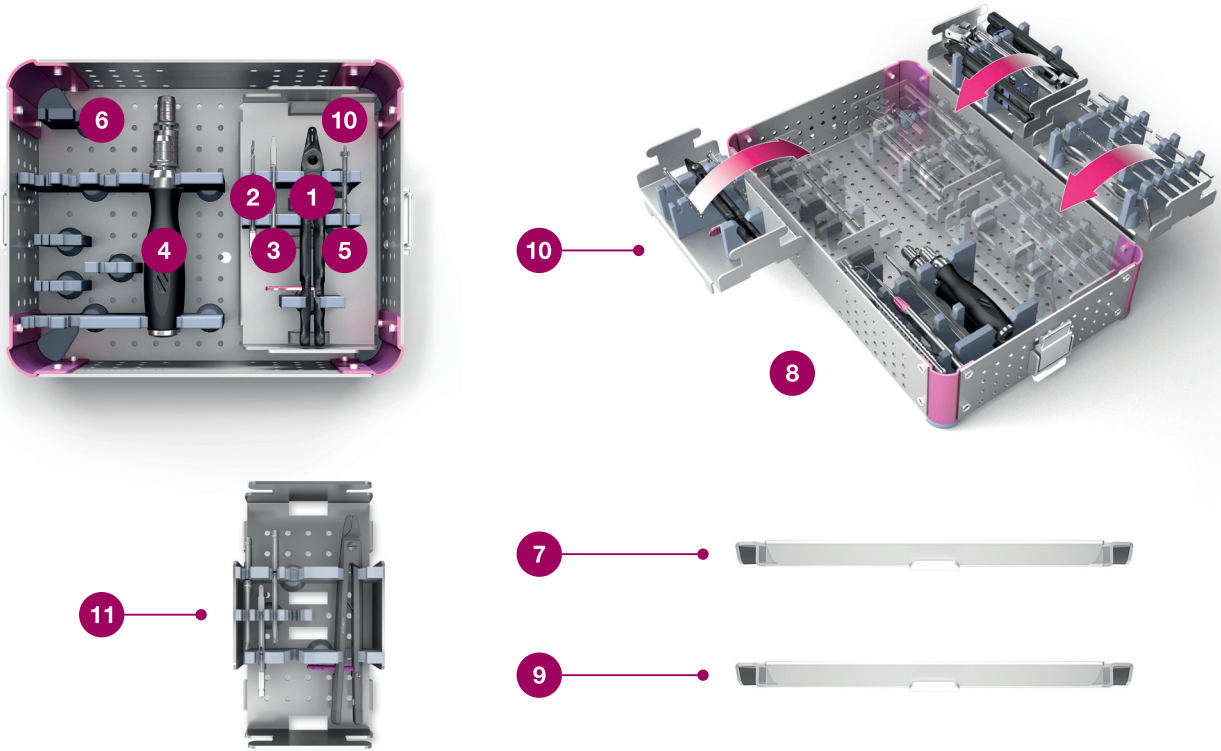

References

Forefoot EXACT & Forefoot COMPLETE: Modular Platform

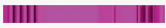

Lync®

	Reference Number	Designation
	CM010030	Lync® S0
	CM010031	Lync® S10
	CM010010	Lync® M0
	CM010011	Lync® M10
	CM010040	Lync® DIP

Instrumentation

Number	Reference Number	Designation
1	XFP04001	Forceps
2	XDB01003	Drill bit Ø 2.3
3	XRA01002	Rasp
4	XHA01001	AO Handle

References

Instrumentation

Number	Reference Number	Designation
5	XRE01002	Surfacing reamer - Optional
6	ACC1005P0003	ForefootEXACT Tray
7	ACC1001P0007	ForefootEXACT Lid
8	ACC1005P0001	ForefootCOMPLETE Tray
9	ACC1001P0002	ForefootCOMPLETE Lid
10	ACC1001P0004	Lync® - Module
11*	ACC1001P0015	Nexis® Lync® Static staples - Module

* ForefootEXACT may be configured with the Lync® & Nexis® module.

lync[®]

Please note:

Carefully read the enclosed Instructions For Use (IFU) and all packaging label information. Devices: Implants: Class IIb-CE1639 / Instruments: Class I / Class Ir-CE1639 / Class IIa-CE1639.

Novastep:

2, Allée Jacques Frimot - 35000 RENNES - France
Tel. : + 33 (0) 2 99 33 86 50 / Fax : + 33 (0) 9 70 29 18 95
contact@novastep-ortho.com / www.int.novastep.life

Reference: LYN-ST-Ed7-07-24-EN