



SURGICAL
TECHNIQUE

enovis™

NEXIS® REARFOOT

Ø5 / Ø7 COMPRESSIVE SCREWS

SCREW SYSTEMS

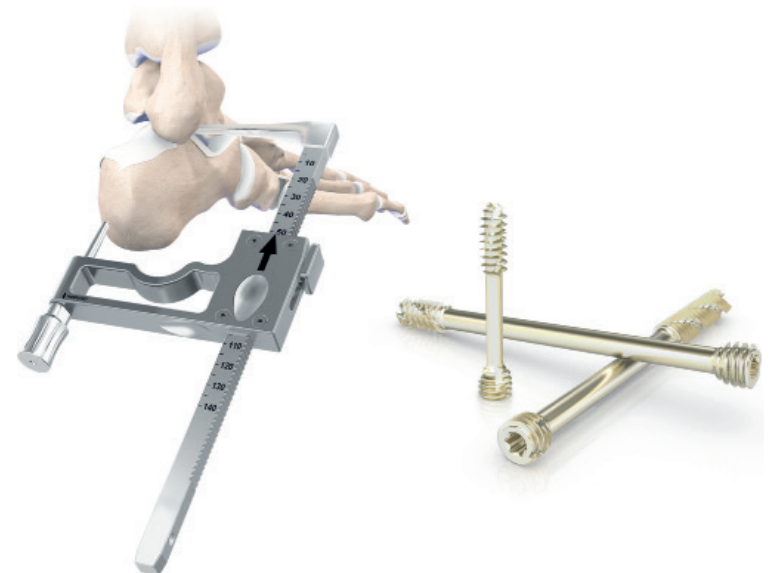

INDICATIONS & CONTRAINDICATIONS	3
TECHNICAL SPECIFICATIONS	4
INSTRUCTIONS FOR USE	9
EXAMPLES OF USE	16
SURGICAL TECHNIQUE	17
ORDERING INFORMATION	21

Novastep® S.A.S is a manufacturer of orthopedic implants and does not practice medicine. This surgical technique was prepared in conjunction with licensed health care professionals. The treating surgeon is responsible for determining the appropriate treatment, technique(s), and product(s) for each individual patient.

See package insert for complete list of potential adverse effects, contraindications, warnings and precautions.

A workshop training is recommended prior to performing your first surgery. All non-sterile devices must be cleaned and sterilized before use.

Multi-component instruments must be disassembled for cleaning. Please refer to the corresponding assembly/disassembly instructions, if applicable. Please remember that the compatibility of different product systems has not been tested unless specified otherwise in the product labeling.

The surgeon must discuss all relevant risks including the finite lifetime of the device with the patient.

Some implants / instruments are not available in all territories. For more information, please contact your local sales representative.

INDICATIONS

The osteosynthesis screws are indicated for arthrosis, hallux valgus, metatarsalgia, and other bone alignment defaults (pes cavus, flatfoot, malalignment secondary to previous trauma).

NOTE: Detailed information on each medical device is provided in the instruction for use. Refer to the instruction for use for a complete list of side effects, warnings, precautions for use and directions for use.

CONTRAINDICATIONS

Osteosynthesis screws should not be used in case of any of the following:

- Severe muscular, neurological or vascular deficiency in the extremity concerned.
- Bone destruction or poor bone quality, likely to impair implant stability.
- Hypersensitivity to vanadium and/or aluminium.

EXAMPLE OF USE

- **Ø5MM COMPRESSIVE SCREW**
Partial or complete Lisfranc arthrodesis
Talonavicular fusion
Calcaneo-cuboid fusion
Lapidus procedure
- **Ø7MM COMPRESSIVE SCREW**
Tibio-talar fusion
Subtalar fusion
Calcaneal osteotomy



REARFOOT SOLUTION

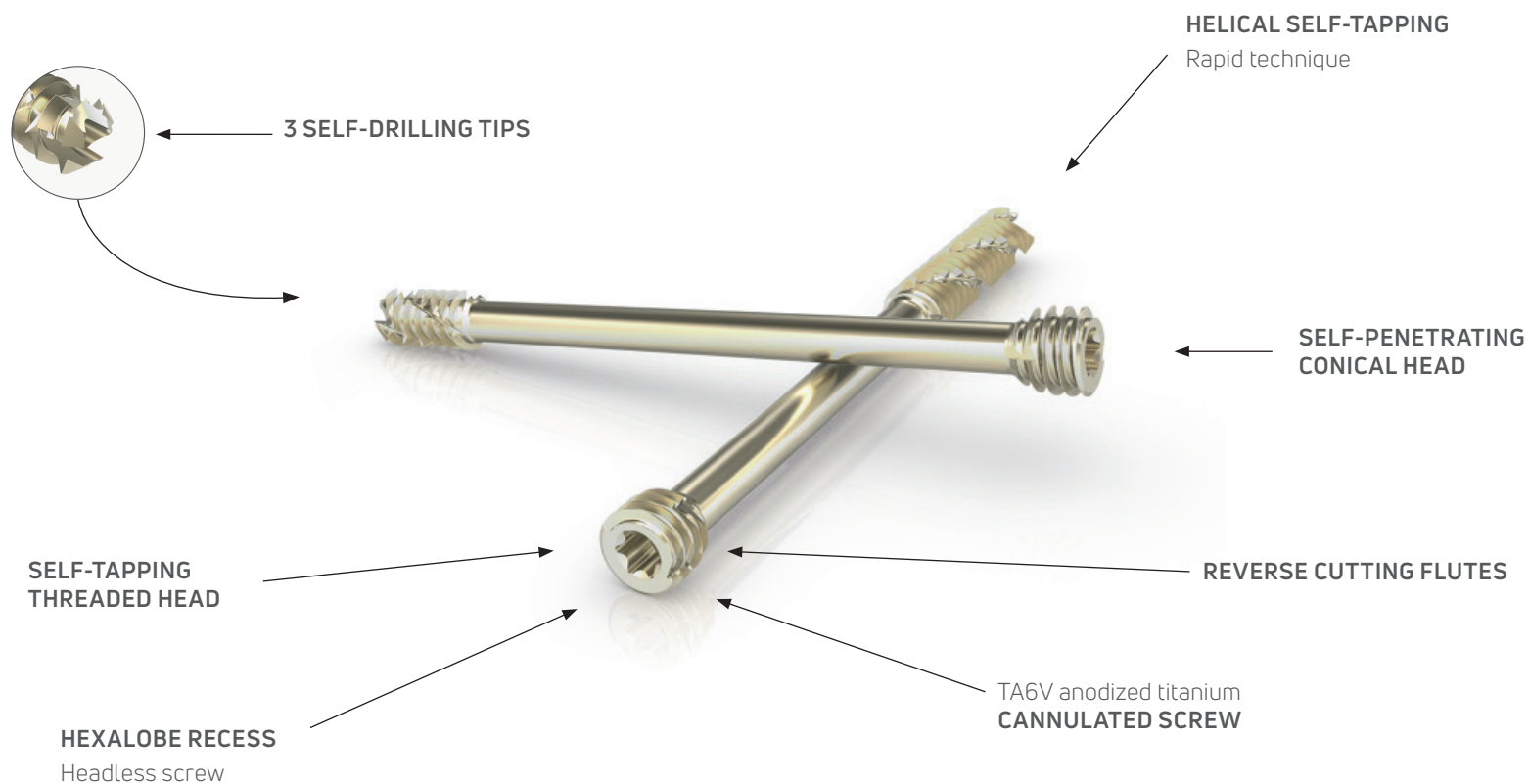

MODULAR INSTRUMENTATION

The instrumentation set is fully modular and customizable with several modules to meet individual surgeon requirements.

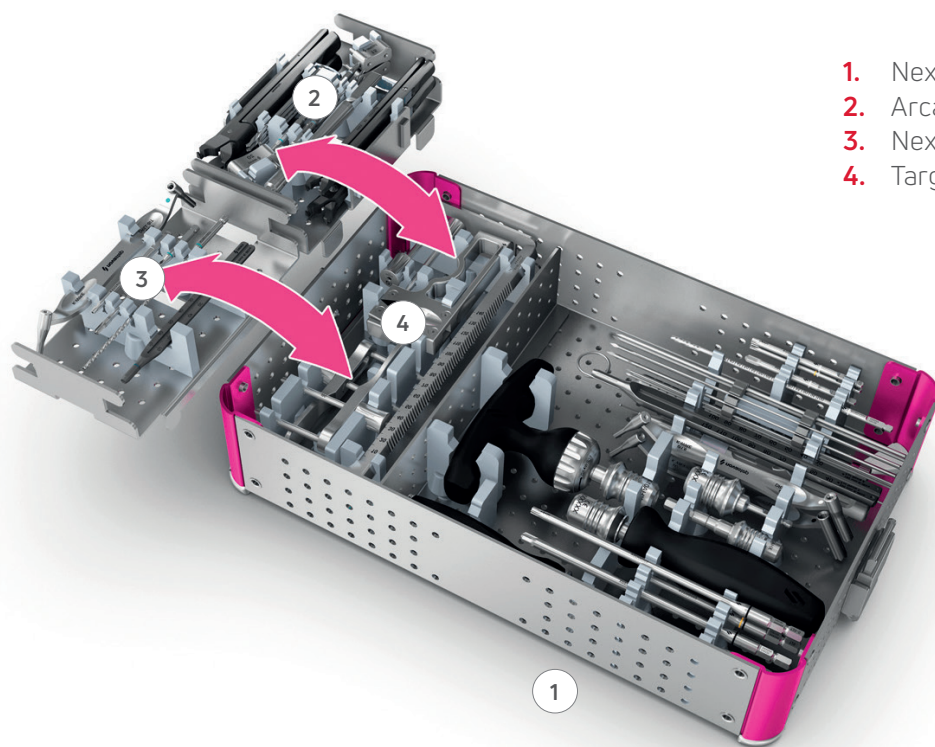

- 1. Nexis® Ø5 / Ø7 tray
 - 2. Arcad® 15-18-20-25 module
 - 3. Nexis® Ø4 module
 - 4. Targeting guide module
- ⋮ These 2 modules can be incorporated together
- ⋮ Also available as a standalone set

ERGONOMIC INSTRUMENTATION

The Nexis® screws can be used with two types of handle: a large AO straight handle or a large AO T handle ratchet for optimum transmission of forces and with ratchet for fast screw insertion.



LARGE AO STRAIGHT HANDLE



LARGE AO T HANDLE RATCHET

Additional graduations on the tip of the ruler and of the T20 AO and T25 large AO screwdriver tips facilitate the identification of soft tissue depth, especially in MIS procedures.

Insert the ruler on the bone for K-wire measurement. In addition, read the depth in soft tissue. This value can be reported on the screwdriver graduated tip to make sure the screw head extremity is flush or lower than the bone cortex.



GRADUATED RULER TIP



GRADUATED SCREWDRIVER TIP

COLOR CODE IDENTIFICATION

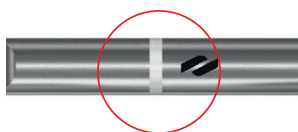

Ø5MM



Ø7MM



SOLID SCREWDRIVER

REARFOOT TARGETING GUIDE FOR Ø5 / Ø7 NEXIS®

Specifically designed for rearfoot indications, the rearfoot targeting guide acts as a clamp to allow for accurate K-wire placement.

FEATURES AND ADVANTAGES

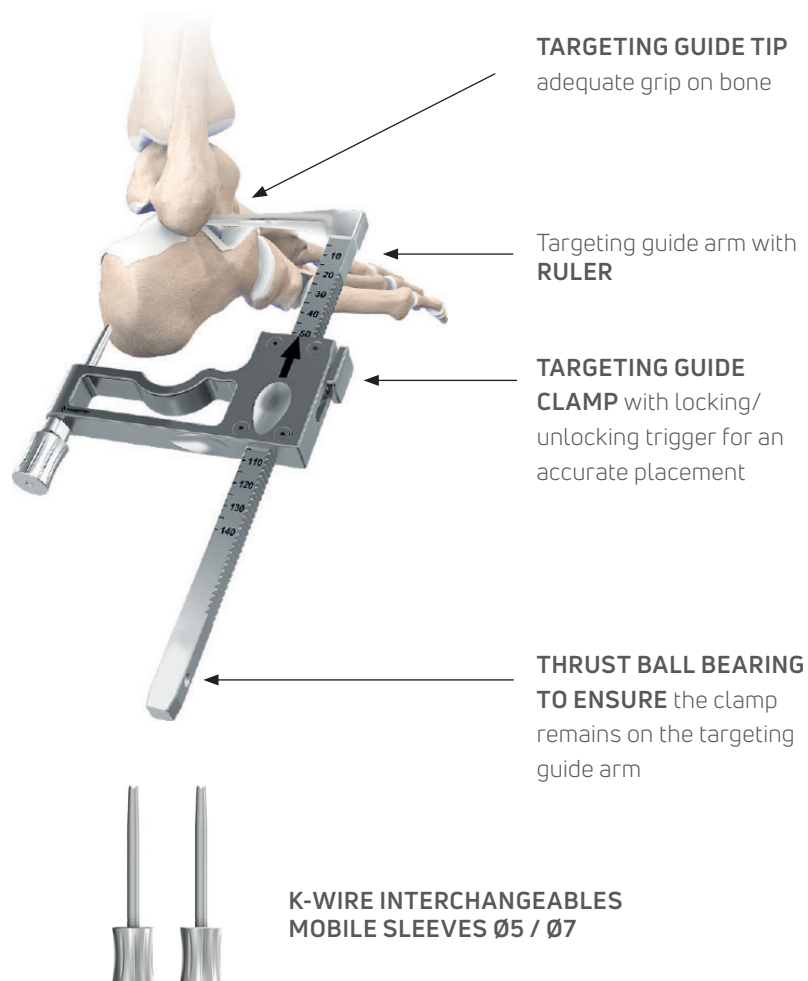

REARFOOT TARGETING GUIDE

- Accurate K-wire placement, positioning entry and exit points.
- Increased accuracy when used in arthroscopic surgery.
- Optimized design with smoothed outer surface of the tip to preserve soft tissue.
- One handed adjustable instrument with trigger rack and pinion design.
- Toothed K-wire sleeve, provides adequate grip on the bone for good stability.
- Accurate screw lengths can be identified by the ruler in the targeting arm.

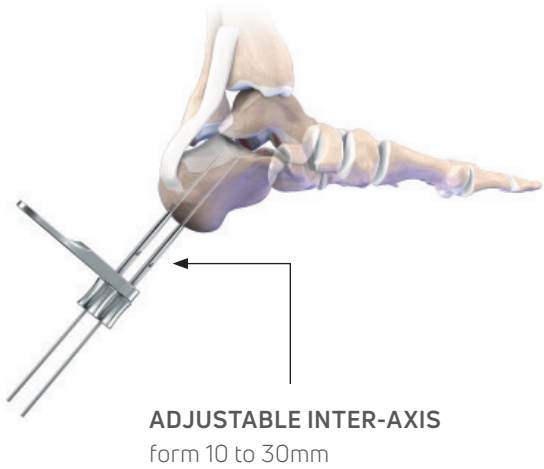

PARALLEL WIRE GUIDE

- Avoids any potential risk of conflict between two Nexis® Ø5 / Ø7 screws with a minimum inter-axis of 10 mm.
- Positioning of 2 parallel screws with an inter-axis from 10 to 30mm.
- Adjustable position of the K-wire sleeve secured with a locking knob.

Mobile locking knob
K-WIRE SLEEVE

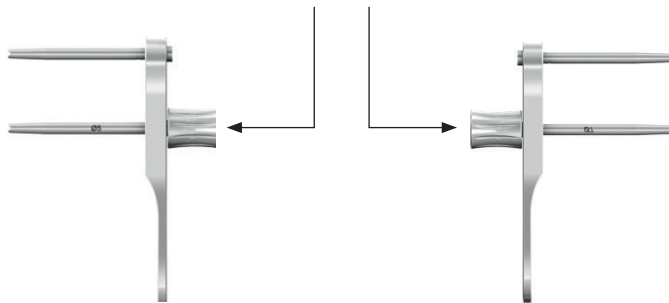

Ø5 / Ø7 NEXIS® INSTRUCTIONS FOR USE

1. K-WIRE INSERTION

The K-wire can be inserted either with the Targeting guide or directly.

The double drill guide Nexis® Ø5 or Nexis® Ø7 can be used before K-wire insertion.

2. SCREW LENGTH ASSESSMENT

A Nexis® ruler can be slid onto the K-wire to identify appropriate screw length.

If the targeting guide has been used to position the K-wire, a direct reading of the length is possible on the graduated arm of the targeting guide, depending on the indications.

A screw length is typically 5mm shorter than that indicated on the ruler.

K-WIRE (FOR USE WITH Ø5 NEXIS® Ø1.6 LG 180MM AND
Ø7 NEXIS® Ø2.2 LG 200MM)

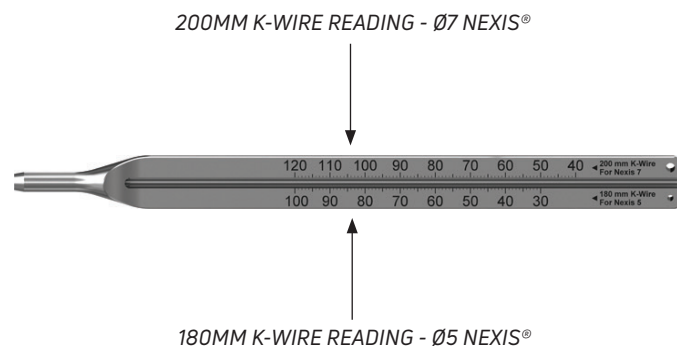

3. SCREW INSERTION

OPTIONAL: SCREW INSERTION PREPARATION

The self-drilling and self-tapping Nexis® screws are efficient in cancellous bone. In dense cortical bone, pre-drilling and/or countersink is recommended, indicated on the ruler.

Option 1: Pre-Drilling

A graduated cannulated drill-bit can be used over the K-wire to drill. Direct reading of appropriate screw length is possible.

Option 2: Screw Head Preparation

A cannulated countersink can be used either manually or preferably attached to the power driver.

The screw is inserted over the K-wire and screwed with the T20 or T25 AO screwdriver tip either manually or attached to the power driver, depending on surgeon's preferences. After correct screw placement, remove the guide wire.

OPTIONAL: SCREW REMOVAL

Each screw has reversed cutting flutes easing the screw extraction. To remove an implanted screw, after cleaning out the screw head use one of the two options below.

Option 1

Insert the adequate K-wire in the cannula of the screw and use the adequate AO screwdriver tip

Option 2

Use the adequate solid screwdriver.



OPTION 1 INSTRUMENTS



OPTION 2 INSTRUMENTS



SCREWDRIVER TIPS



REMOVAL OPTION 1 INSTRUMENTS



REMOVAL OPTION 2 INSTRUMENTS

NOTE: Instruments can be connected to power or used manually attached to straight handle or T-handle. Adaptors are available in the Nexis® set to suit the power tools type available in the OR.

Ø5 NEXIS® INSTRUMENTS



ADAPTATOR 1/4" HEX LARGE AO - AO



T20 AO SCREWDRIVER TIP

Ø7 NEXIS® INSTRUMENTS

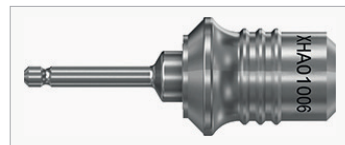
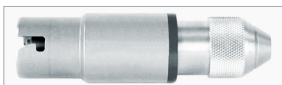

ADAPTATOR AO - LARGE AO 1/4" HEX (Ø7 NEXIS®)



T25 LARGE AO SCREWDRIVER TIP

TARGETING GUIDE AND PARALLEL WIRE GUIDE

Unlock the clamp by pressing the button to move it forward or backward.

1. Insert the clamp on the targeting guide arm. The anti-return rack and pinion system enable to hold the chosen position.
2. Insert the Nexis® K-wire sleeve.

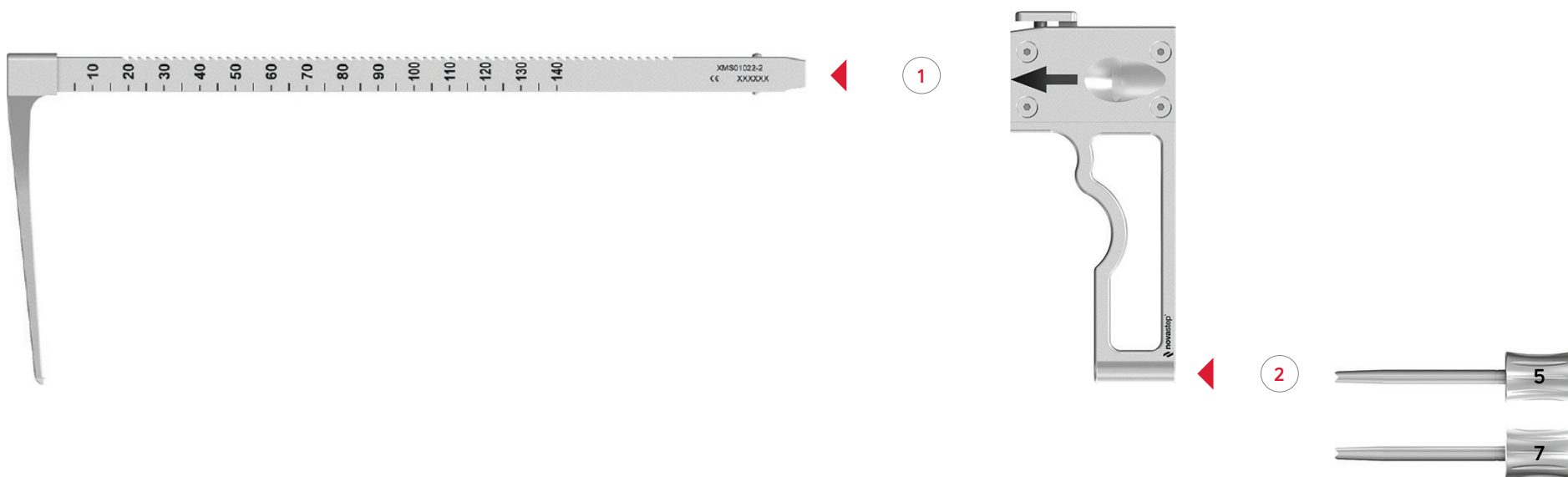

OPTIONAL: Depending on the indicated use, direct reading of the needed screw length is possible.

3. Determine the Entry and Exit point to position the targeting guide which acts as a clamp. Insert the K-wire until it stops at the desired position.
4. Keep the K-wire in place and remove the Nexis® K-wire sleeve (A), the clamp (B) and the targeting guide arm (C).

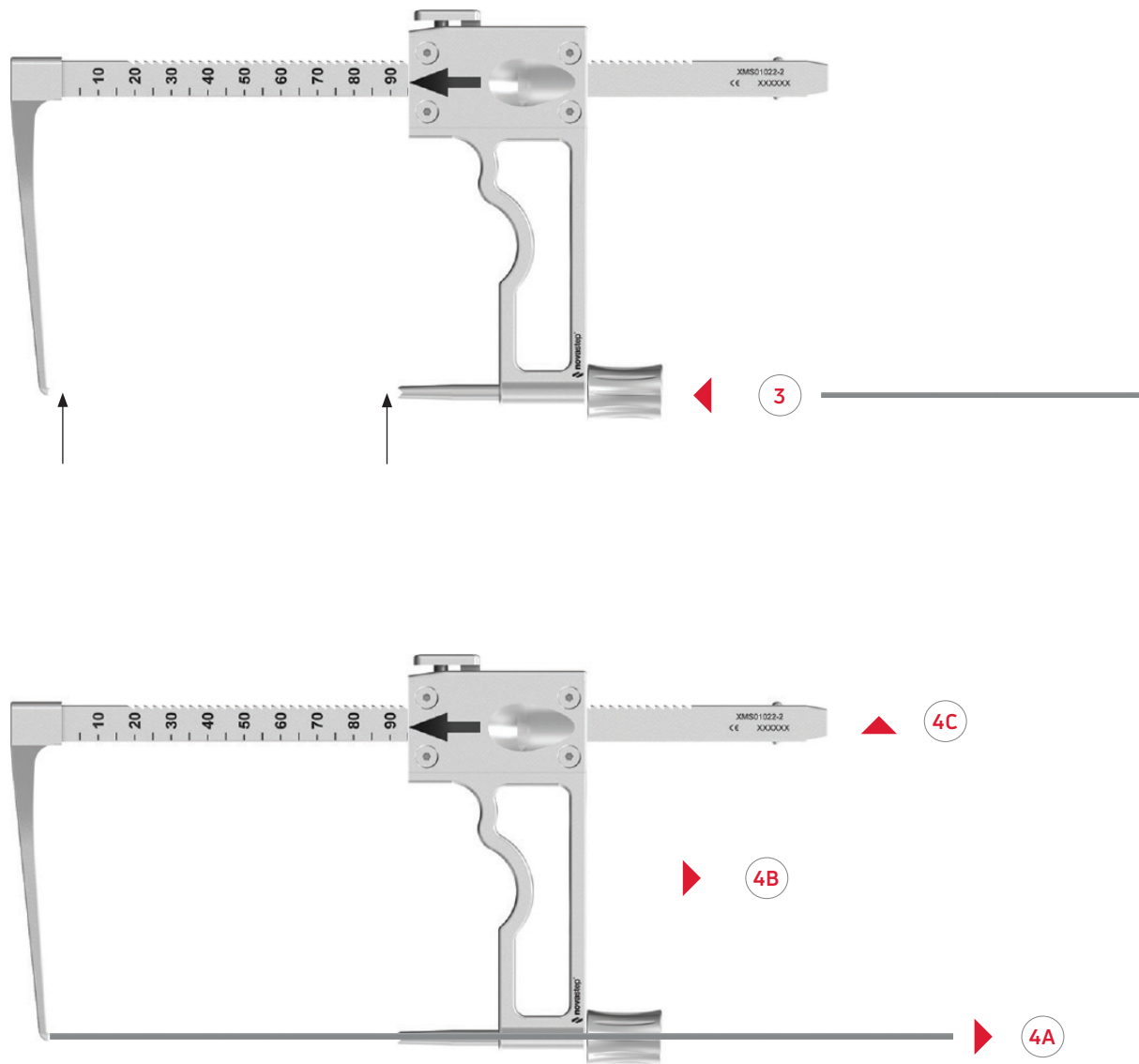

OPTIONAL: Implant two screws with the parallel wire guide.

5. After K-wire positioning, insert the parallel wire guide on the K-wire. Define the correct inter-axis (1) and lock the knob to secure the sleeve position (2).
6. Insert the second K-wire in the sleeve. Remove the parallel wire guide to insert the Nexis® screws.

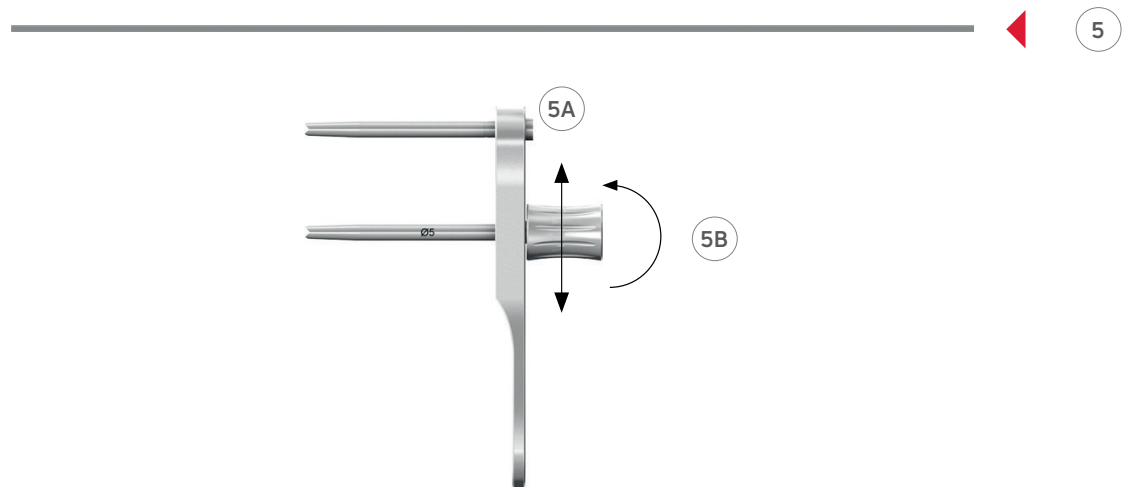

NOTE: Depending on the indications, the parallel wire guide can be used as standalone, without prior use of the targeting guide.

After K-wire positioning, follow the instructions for use of Nexis® screws (cf p 9-11).

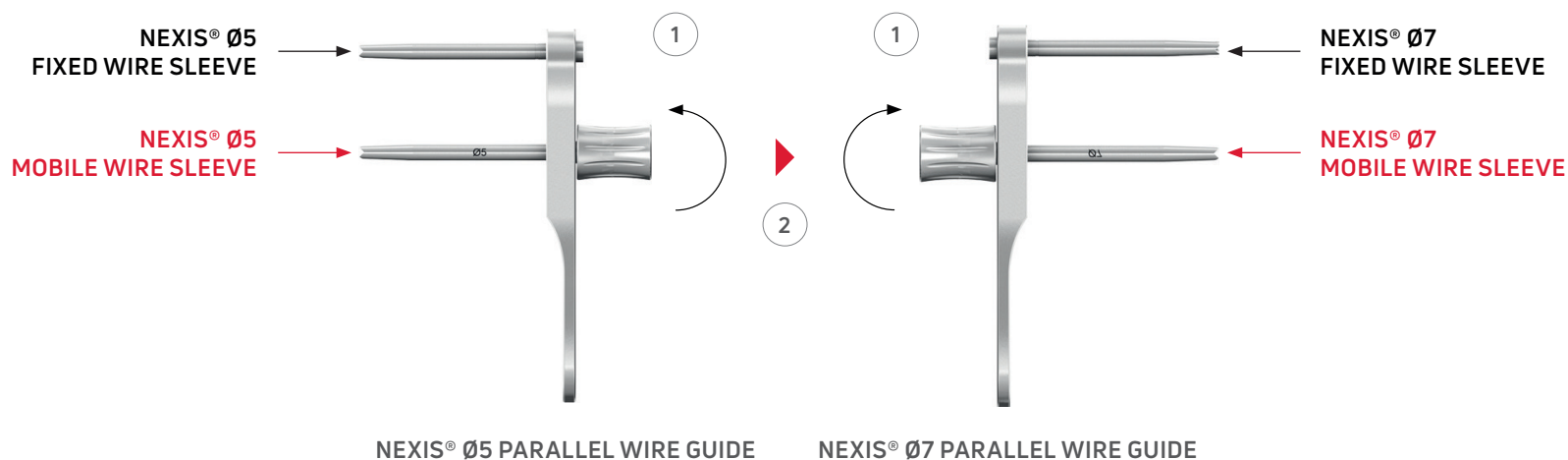

TIP: For inserting two screws with different diameters, the Nexis® Ø5 parallel wire guide can be used over the Ø1.6 K-wire. The Ø7 Nexis® parallel wire guide can be used over Ø2.2 K-wire.

If needed, it is possible to swap the mobile wire sleeves by unscrewing them off the parallel wire guide.

CLEANING & STERILIZATION TIP: For appropriate cleaning of the instruments, disassemble all pieces. Remove the K-wire sleeve from the clamp and the clamp from the targeting guide arm. Unscrew the K-wire sleeve and remove it from the parallel guide.

The rearfoot targeting guide aides in the following procedures:



SUBTALAR JOINT FUSION

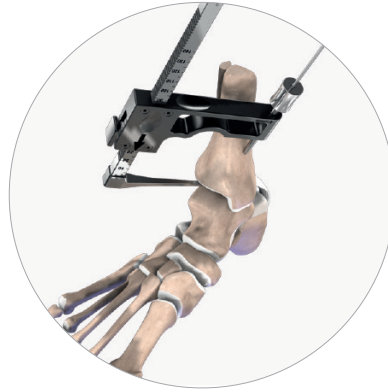

TIBIOTALAR JOINT FUSION / ANKLE FUSION

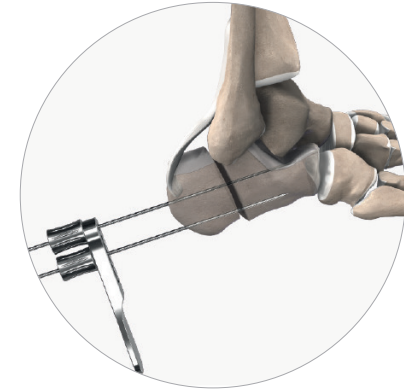

CALCANEAL SLIDE OSTEOTOMY



TALO-NAVICULAR FUSION



CALCANEAL-CUBOID FUSION

This surgical technique describes a subtalar arthrodesis procedure.

1. INCISION & EXPOSURE

Make a cut on the lateral aspect of the ankle and expose the subtalar joint. Position an open arms distractor between the calcaneus and the talus.

Sterile threaded k-wires are available for use with the distractor. Threaded K-wire tips provide adequate grip when compared to smooth k-wires which avoid retractor migration when distracting the joint.

Distract the joint to prepare the joint surfaces for fusion by removing the cartilage on superior aspect of the calcaneus and inferior aspect of the talus with an osteotome or a curette until arriving in the presence of bleeding subchondral bone (**FIGURE 1**).

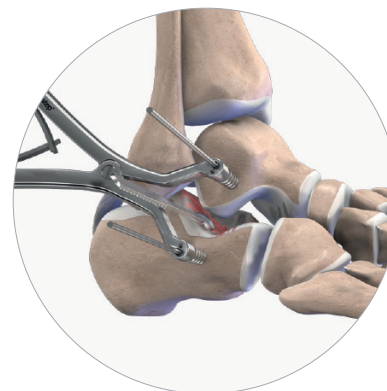

FIGURE 1

2A. TARGETING GUIDE SET UP

Assemble the targeting guide. Make a cut on the posterior aspect of the calcaneum, at the entry point level of the first K-wire. Position the tip of the targeting guide in the subtalar joint, at the desired exit point of the first K-wire.

Slide the clamp on the targeting guide arm to position the Nexis® Ø 7 K-wire sleeve in the incision. The no-return ratcheted system and pinion system maintain the clamp in place (**FIGURE 2**).

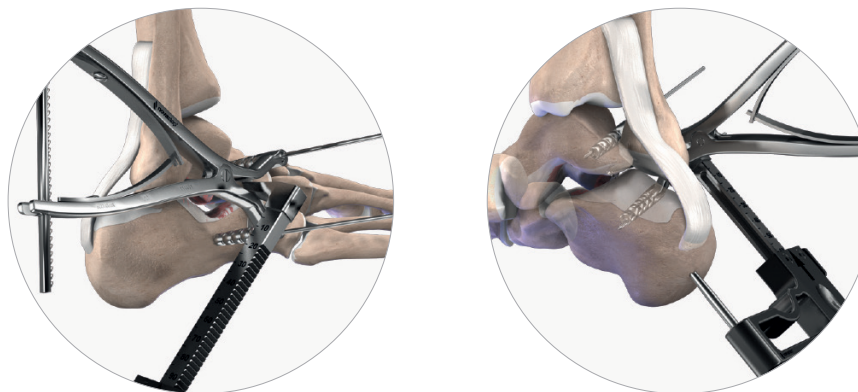

FIGURE 2

2B. ALTERNATE TARGETING GUIDE POSITIONING

When the subtalar joint surface is prepared, remove the open arms distractor. Assemble the targeting guide. Position the tip of the targeting guide on the tarsal sinus. Slide the clamp on the targeting guide arm to position the Nexis® Ø 7 K-wire sleeve on the posterior aspect of the calcaneus, at the entry point level of the first K-wire (FIGURE 3).



FIGURE 3

3. K-WIRES POSITIONING WITH TARGETING GUIDE AND PARALLEL WIRE GUIDE

Insert a Ø2.2 lg 200 K-wire in the Nexis® Ø7 K-wire sleeve through the calcaneus until it reaches the tip of the targeting guide (FIGURE 4).

Keep the K-wire in place and remove the Nexis® K-wire sleeve with the clamp, and the targeting guide arm (FIGURE 5).

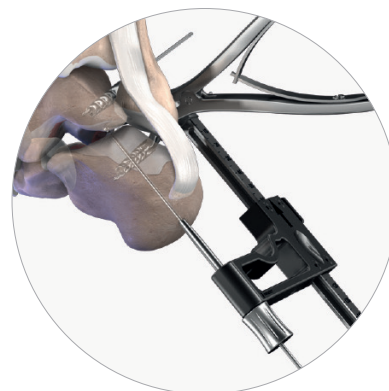

FIGURE 4

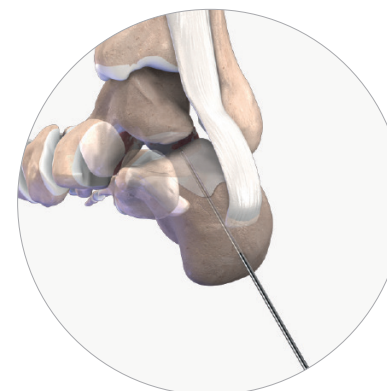

FIGURE 5

Insert the Nexis® Ø 7 parallel wire guide on the K-wire (FIGURE 6).

Insert the second K-wire Ø 2.2 lg 200 in the Nexis® Ø 7 K-wire sleeve. Remove the parallel wire guide, letting the two K-wires in position (FIGURE 7).

Remove the open arms distractor to reduce the subtalar joint. Insert both K-wires deeper into the talus until the appropriate depth with fluoroscopic guidance.

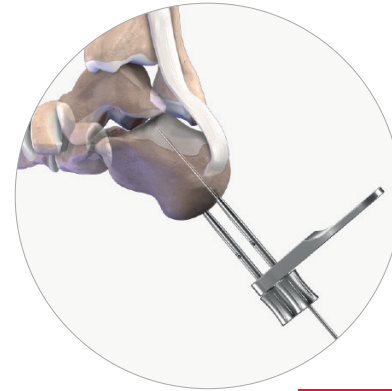

FIGURE 6

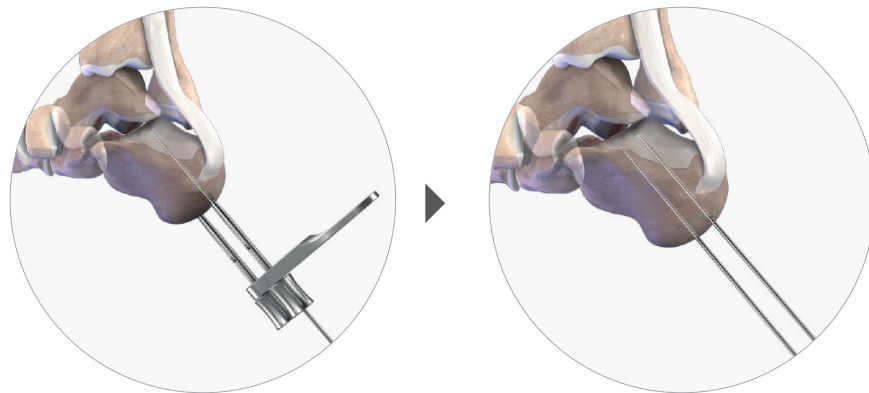

FIGURE 7

4A. SCREW INSERTION - OPTION 1

NOTE: A double drill guide can be positioned over the K-wire (**FIGURE 8**).

Pre-drilling is recommended in the presence of dense cortical bone.

Nexis® cannulated drill bit Ø 4.8 is used to prepare the insertion of the screw. Use the drill bit over the K-wire until the appropriate depth. Screw length can be read directly off of the graduated drill bit (**FIGURE 9**).

NOTE: The Nexis® Ø6 countersink can be used to prepare the location of the screw head (**FIGURE 10**).

Use the T25 large AO screwdriver tip over the K-wire to insert the Ø7 Nexis® screw manually or connected to the power tool. Finish the insertion by hand until the screw is correctly positioned (**FIGURE 11**).



FIGURE 8



FIGURE 9

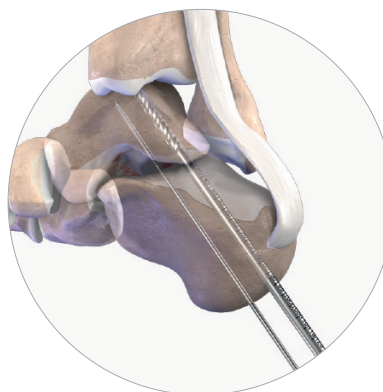

FIGURE 10

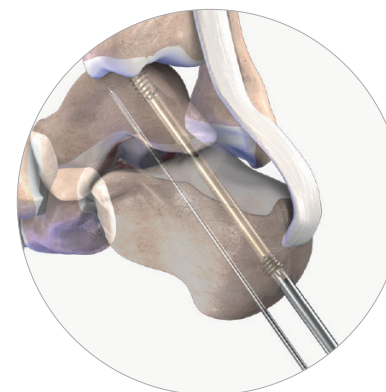

FIGURE 11

4B. SCREW INSERTION - OPTION 2

Assess the appropriate screw length with the graduated Nexis® ruler (**FIGURE 12**).

Use the T25 large AO screwdriver tip over the K-wire to insert the Ø7 Nexis® screw manually or with the power tool. Finish the insertion by hand until the screw is correctly positioned (**FIGURE 13**).

Confirm the placement and length of the screws under fluoroscopy and stability of the construct. Remove the K-wires before closing and dressing (**FIGURE 14**).

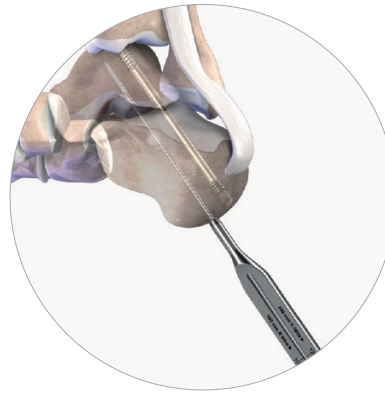

FIGURE 12

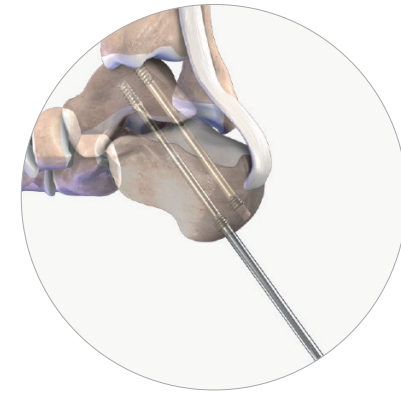

FIGURE 13



FIGURE 14

COMPRESSIVE SCREWS

LENGTH (mm)	Ø5 mm	Ø7 mm SHORT THREAD	Ø7 mm LONG THREAD
30	SC060030	-	-
32	SC060032	-	-
34	SC060034	-	-
36	SC060036	-	-
38	SC060038	-	-
40	SC060040	SC070040	SC080040
42	SC060042	-	-
44	SC060044	-	-
45	-	SC070045	SC080045
46	SC060046	-	-
48	SC060048	-	-
50	SC060050	SC070050	SC080050
55	SC060055	SC070055	SC080055
60	SC060060	SC070060	SC080060
65	SC060065	SC070065	SC080065
70	SC060070	SC070070	SC080070
75	SC060075	SC070075	SC080075
80	SC060080	SC070080	SC080080
85	SC060085	SC070085	SC080085
90	SC060090	SC070090	SC080090
95	SC060095	SC070095	SC080095
100	SC060100	SC070100	SC080100
105	-	SC070105	SC080105
110	-	SC070110	SC080110
115	-	SC070115	SC080115
120	-	SC070120	SC080120

K-WIRES

PART NO.	DESCRIPTION
-	K-WIRE Ø1.6 LG 180 TR/RD ⁽¹⁾
-	K-WIRE Ø 2.2 LG 200 TR/RD ⁽²⁾

⁽¹⁾K-wire supplied separately - Medetechnik® K-wire (33-T10-R-16-180) or Novastep® K-wire (CKW01004) are available depending on your market.

⁽²⁾K-wire supplied separately - Medetechnik® K-wire (33-T10-R-22-200) or Novastep® K-wire (CKW01011) are available depending on your market.

INSTRUMENTS

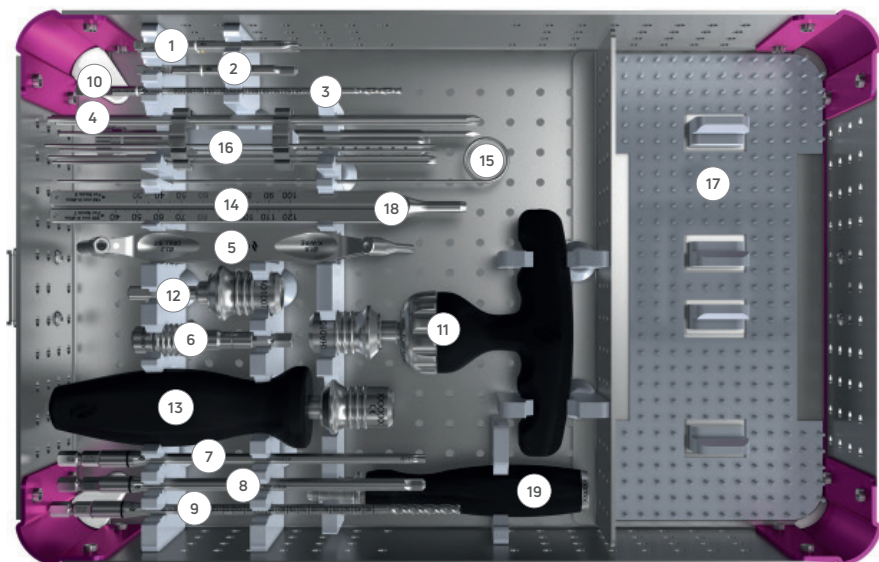

NEXIS® Ø5

#	DESCRIPTION	PART NO.	QTY
1	T20 AO SCREWDRIVER TIP	XSD05001	2
1	SOLID T20 AO SCREWDRIVER TIP	XSD05002	1
2	COUNTERSINK Ø4.9	XRE01008	1
3	CANNULATED DRILL BIT Ø3.2	XDB01009	1
4	K-WIRE Ø1.6 LG 180 TR/RD ⁽¹⁾	-	5
5	DOUBLE DRILL GUIDE FOR SCREW Ø5	XDG01015	1
6	ADAPTATOR 1/4" HEX - AO	XHA01005	1

⁽¹⁾K-wire supplied separately - Mediatechnik® K-wire (33-T10-R-16-180) or Novastep® K-wire (CKW01004) are available depending on your market.

NEXIS® Ø7

#	DESCRIPTION	PART NO.	QTY
7	T25 AO SCREWDRIVER TIP	XSD06003	2
7	SOLID T25 AO SCREWDRIVER TIP	XSD06002	1
8	COUNTERSINK Ø6	XRE01009	1
9	CANNULATED DRILL BIT Ø4.8	XDB01010	1
10	K-WIRE Ø2.2 LG 200 TR/RD ⁽²⁾	-	5
5	DOUBLE DRILL GUIDE FOR SCREW Ø7	XDG01016	1
12	ADAPTATOR AO LARGE 1/4" HEX	XHA01006	1

⁽²⁾K-wire supplied separately - Mediatechnik® K-wire (33-T10-R-22-200) or Novastep® K-wire (CKW01005) are available depending on your market.

UNIVERSAL INSTRUMENTATION

#	DESCRIPTION	PART NO.	QTY
11	LARGE AO T HANDLE RATCHET	XHA01004	1
13	LARGE AO STRAIGHT HANDLE	XHA01003	1
14	RULER LG 180/200	XGA01007	1
15	CLEANING PIN Ø 1.6	XKW01003	1
16	K-WIRE HOLDER	ACC1008P0004	1
-	TRAY	ACC1008P0001	1
-	LID	ACC1008P0002	2
17	SILICONE MAT	ACC1008P0003	1
18	DEPTH GAUGE	XGA01002	1
19	AO HANDLE	XHA01001	1

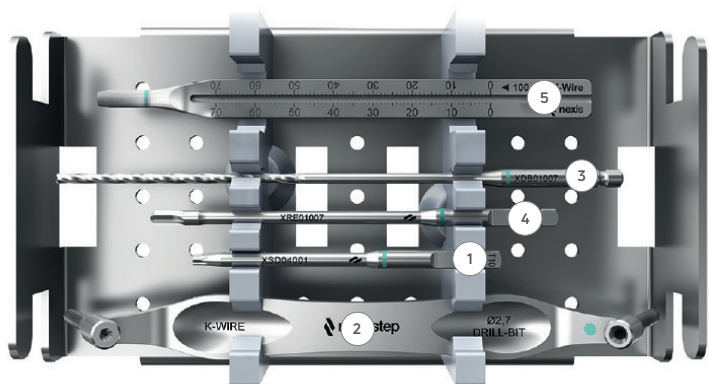

Ø4 NEXIS® MODULE

#	DESCRIPTION	PART NO.	QTY
-	MODULE	ACC1002P0004	1
1	T10 AO SCREWDRIVER TIP	XSD04001	1
2	DOUBLE DRILL GUIDE FOR SCREW Ø4	XDG01009	1
3	CANNULATED DRILL BIT Ø2.7	XDB01007	1
4	COUNTERSINK Ø3.7	XRE01007	1
5	RULER LG 100	XGA01004	1
-	CLEANING PIN Ø1.4	XKW01002	1
-	K-WIRE TUBE	XMS01001	1
-	K-WIRE Ø1.4 LG 100 TR/RD ⁽³⁾	-	5

⁽³⁾K-wire supplied separately - Medetechnik® K-wire (33-T10-R-14-100) or Novastep® K-wire (CKW01002) are available depending on your market.

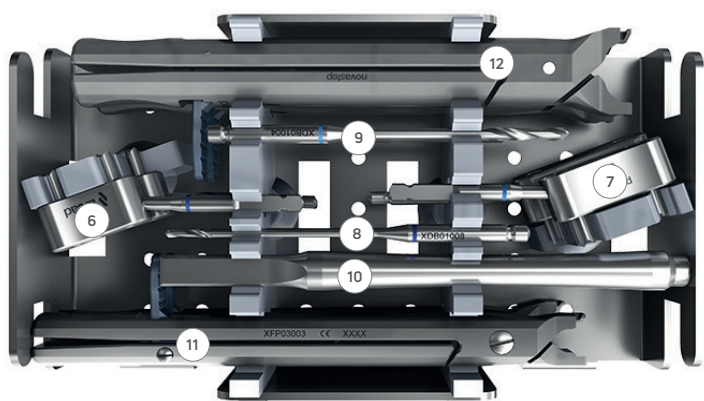

ARCAD® 15-18-20-25

#	DESCRIPTION	PART NO.	QTY
-	MODULE	ACC1005P0007	1
6	DRILL GUIDE - ARCAD® 15	XDG01003	1
6	DRILL GUIDE - ARCAD® 18	XDG01004	1
7	DRILL GUIDE - ARCAD® 20	XDG01005	1
7	DRILL GUIDE - ARCAD® 25	XDG01006	1
8	POSITIONING PIN Ø2	XPP01001	2
9	POSITIONING PIN Ø3	XPP01002	2
10	IMPACTOR	XMS01002	1
8	DRILL BIT Ø2	XDB01008	1
9	DRILL BIT Ø3	XDB01004	1
11	FORCEPS - ARCAD® 15	XFP03003	1
11	FORCEPS - ARCAD® 18	XFP03004	1
12	FORCEPS - ARCAD® 20	XFP03005	1
12	FORCEPS - ARCAD® 25	XFP03006	1

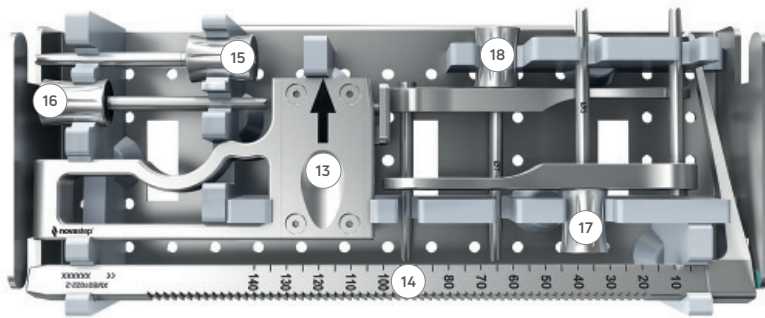

NEXIS® TARGETING GUIDE

#	DESCRIPTION	PART NO.	QTY
-	MODULE	ACC1012P0003	1
13	TARGETING GUIDE CLAMP	XMS01022-1	1
14	TARGETING GUIDE ARM	XMS01022-2	1
15	K-WIRE SLEEVE - NEXIS® Ø5	XMS01022-3	1
16	K-WIRE SLEEVE - NEXIS® Ø7	XMS01022-4	1
17	PARALLEL WIRE GUIDE - NEXIS® Ø5	XMS01023	1
18	PARALLEL WIRE GUIDE - NEXIS® Ø7	XMS01024	1

TARGETING GUIDE TRAY

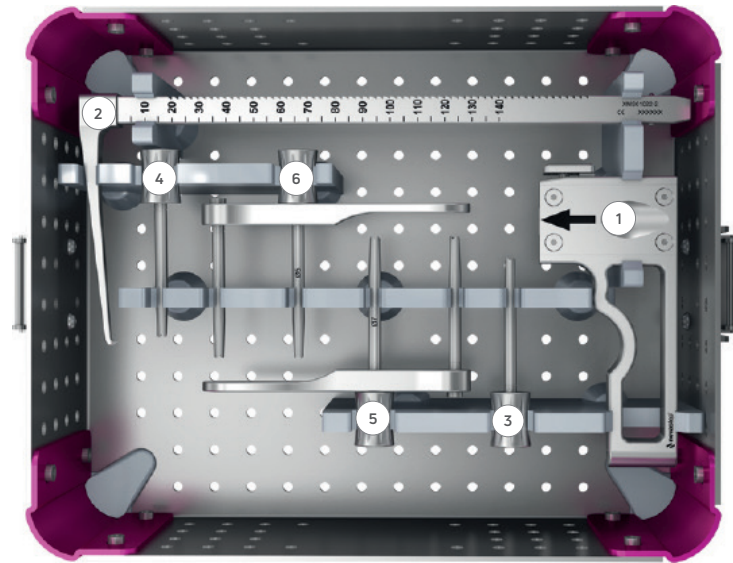

#	DESCRIPTION	PART NO.	QTY
-	TRAY	ACC1012P0001	1
-	LID	ACC1012P0002	1
1	TARGETING GUIDE CLAMP	XMS01022-1	1
2	TARGETING GUIDE ARM	XMS01022-2	1
3	K-WIRE SLEEVE - NEXIS® Ø5	XMS01022-3	1
4	K-WIRE SLEEVE - NEXIS® Ø7	XMS01022-4	1
5	PARALLEL WIRE GUIDE - NEXIS® Ø5	XMS01023	1
6	PARALLEL WIRE GUIDE - NEXIS® Ø7	XMS01024	1

enovis.

T +33 (0) 2 99 33 86 50 F +33 (0) 9 70 29 18 95

Legal manufacturer: Novastep® S.A.S
2 Allée Jacques Frimot | 35000 Rennes | France
contact-intfa@enovis.com
www.int.novastep.life
Copyright © 2024 Enovis Foot and Ankle

Carefully read the enclosed Instructions For Use (IFU) and all packaging label information. Devices: Implants: Class IIb-CE1639 / Instruments: Class I / Class Ir-CE1639 / Class IIa-CE1639.

REFERENCE: NEX-REAR-ST-ED8-02-26-EN