



SURGICAL
TECHNIQUE

enovis™

NEXIS® FOREFOOT

Ø2 SNAP-OFF SCREWS & Ø2.3 / MIS Ø2.7 / Ø2.9 / Ø4 COMPRESSIVE SCREWS

SCREW SYSTEMS



INDICATIONS & CONTRAINDICATIONS	3
TECHNICAL SPECIFICATIONS	4
SURGICAL TECHNIQUE	10
ORDERING INFORMATION	18

Novastep® S.A.S is a manufacturer of orthopedic implants and does not practice medicine. This surgical technique was prepared in conjunction with licensed health care professionals. The treating surgeon is responsible for determining the appropriate treatment, technique(s), and product(s) for each individual patient.

See package insert for complete list of potential adverse effects, contraindications, warnings and precautions.

A workshop training is recommended prior to performing your first surgery. All non-sterile devices must be cleaned and sterilized before use.

Multi-component instruments must be disassembled for cleaning. Please refer to the corresponding assembly/disassembly instructions, if applicable. Please remember that the compatibility of different product systems has not been tested unless specified otherwise in the product labeling.

The surgeon must discuss all relevant risks including the finite lifetime of the device with the patient.

Some implants / instruments are not available in all territories. For more information, please contact your local sales representative.

INDICATIONS

The osteosynthesis screws are indicated for arthrosis, hallux valgus, metatarsalgia, and other bone alignment defaults (pes cavus, flatfoot, malalignment secondary to previous trauma).

CONTRAINDICATIONS

Osteosynthesis screws should not be used in case of any of the following:

- Severe muscular, neurological or vascular deficiency in the extremity concerned.
- Bone destruction or poor bone quality, likely to impair implant stability.
- Hypersensitivity to vanadium and/or aluminium.

EXAMPLE OF USE

- **Ø2MM SNAP-OFF**
Weil osteotomy
- **Ø2.7MM MIS**
- **Ø2.3 & Ø2.9MM**
Scarf & Chevron osteotomies, P1 osteotomy
- **Ø4MM**
MTP & Cuneo-metatarsal arthrodesis



NOTE: Detailed information on each medical device is provided in the instruction for use. Refer to the instruction for use for a complete list of side effects, warnings, precautions for use and directions for use.

NEXIS® MIS Ø2.7

1. CANNULATED SCREW: *EXTRA-SHARP* Ø1.2 K-WIRE

2. ELLIPTIC BEVELED HEAD (30°)

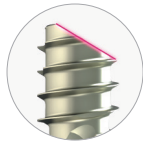

Maximizes cortical anchorage and preservation of soft tissue

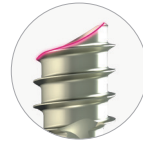

Allows for additional angular rotation to preserve the burial of the head

3. EXACT2-T RECESS

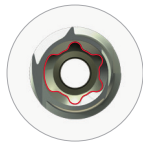

Specific & universal

4. POSITIVE LOCKING CHANNEL

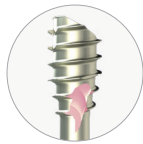

5. SELF-DRILLING & SELF-TAPPING



Penetrating sharp tips facilitate insertion

6. DEEP DUAL THREAD

Maximized anchorage & compression

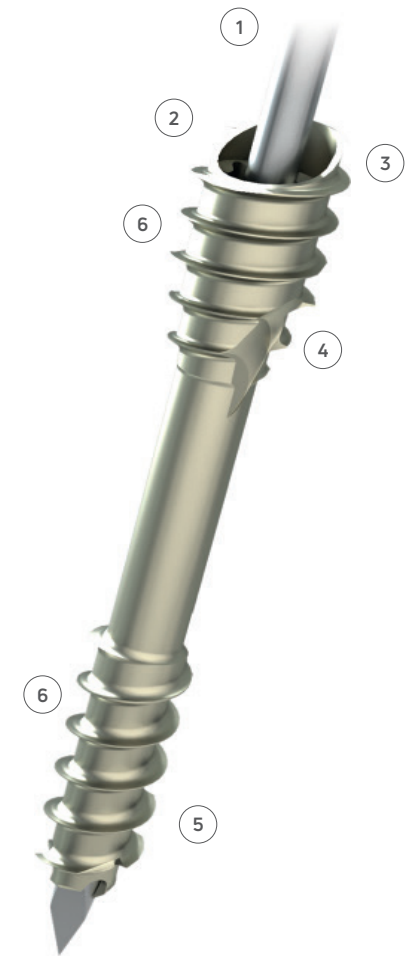

Ø2.7 NEXIS® MIS

NEXIS® MIS Ø2.7 INSTRUMENTATION



EXTRA-SHARP Ø 1.2 K-WIRE

Ø 1.2 mm: provides greater stiffness*

Sharpened tip: allows for easy angulated insertion



EXACT2-T8 SCREWDRIVER

RECESS

- **Specific:** Easy indexing of the Exact2-T8 AO screwdriver tip
- **Accurate:** Ensures unique positioning of the screwdriver tip
- **Universal:** Possible removal with standard instrumentation

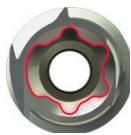

SCREWDRIVER TIP

The laser marking and bevel of the Exact2-T8 AO screwdriver tip facilitate the proper placement of the screw head.

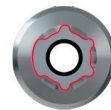

LASER MARKING BEVEL

*Greater stiffness than a Ø0.9 k-wire

NEXIS® MIS Ø2.7 MINI TRAY

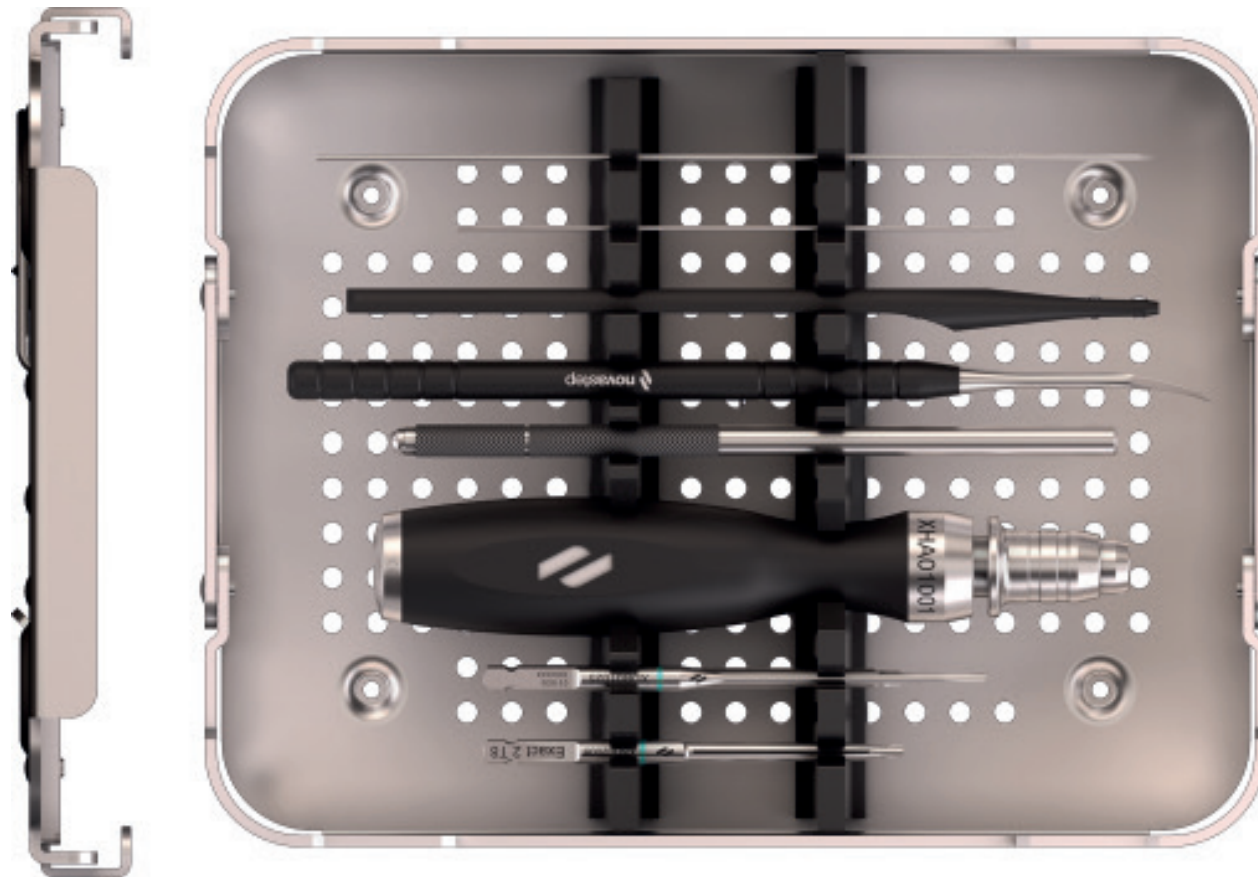

**Extra-sharp K-wire & Exact2-T8 AO screwdriver tip are optional in the Nexis® ForefootCOMPLETE & ForefootEXACT trays*

NEXIS® Ø2 / Ø2.3 / Ø2.9 / Ø4

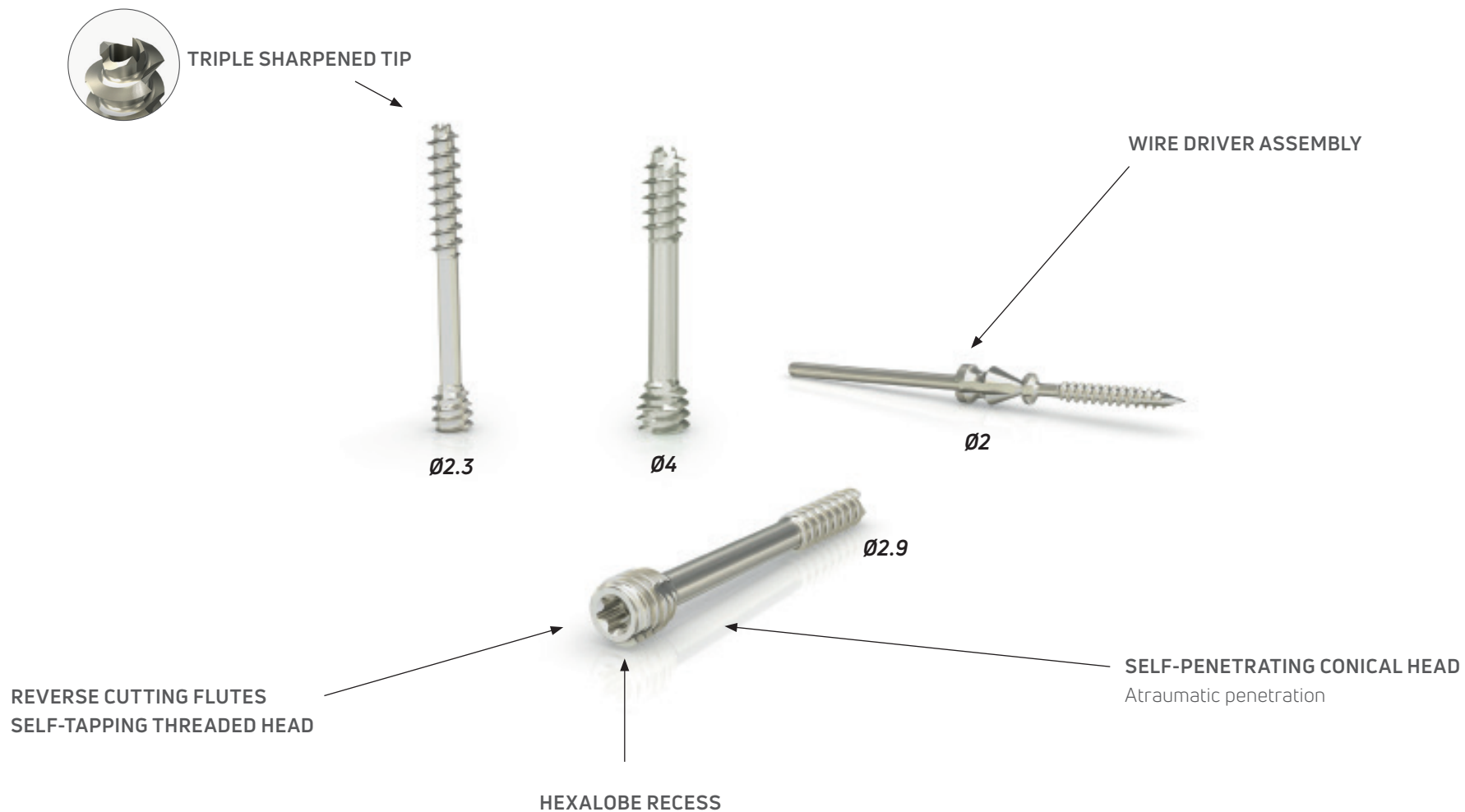

NEXIS® MODULAR INSTRUMENTATION

A modular concept allowing customization of the ancillary according to the preferences of the practitioner or the indication. There are two versions available:

- **ForefootCOMPLETE:** possibility of accommodating Nexis® screw, Arcad® staple and Lync® intramedullary implant modules in a complete tray.
- **ForefootEXACT:** possibility of interchanging the modules Nexis®, Arcad® staple and Lync® intramedullary implant for space saving in a half-tray.

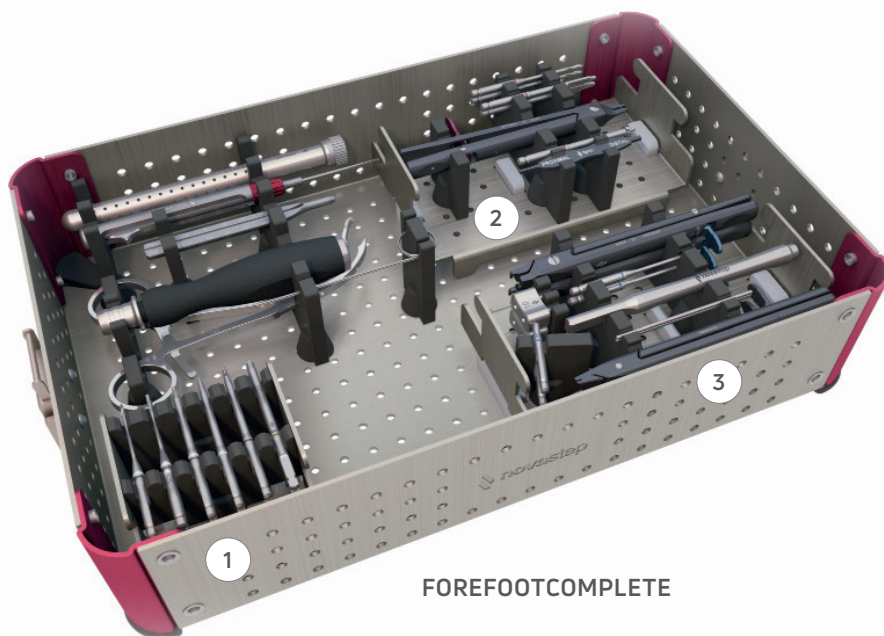

- FOREFOOTEXACT**
1. Nexis® screw module
 2. Lync® intramedullary implant module
 3. Arcad® staple module

NEXIS® DEDICATED INSTRUMENTATION

DEDICATED INSTRUMENTATION

Dedicated instrumentation for each osteotomy: Weil, Scarf, Chevron, M1.

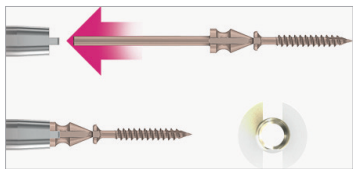

SNAP-OFF AO SCREWDRIVER TIP

Snap-off screws compatible for use with wire driver or for manual fixation with specific snap-off screwdriver tip.



**SPOON FOR
WEIL OSTEOTOMY**
(XMS01007)*



**SCARF
FORCEPS**
(XFP01001)*



**CHEVRON
FORCEPS**
(XFP01004)*

COLOR CODED

Color coded equipment permits at-a-glance instrument identification.

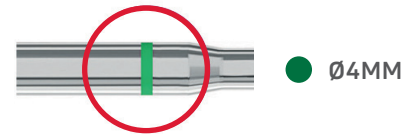
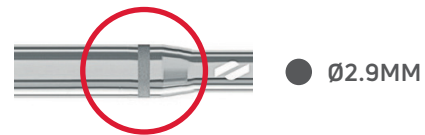
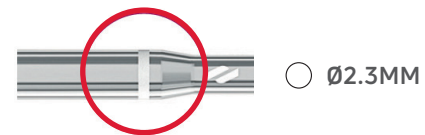
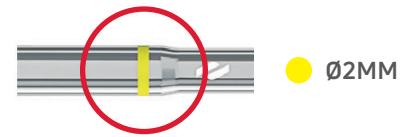

1. CHEVRON OSTEOTOMY

1.1 INCISION & EXPOSURE

A medial incision is performed (2 to 3 cm) for first metatarsal-phalangeal joint exposure. The first metatarsal-phalangeal joint capsule is incised according to the surgeon's preference to expose the first metatarsal medial eminence.

1.2 OSTEOTOMY & K-WIRE INSERTION

Perform the Chevron Osteotomy with an oscillating saw blade. When reduction is achieved, stabilize the two bone fragments with a extra-sharp K-wire Ø 1.2 mm placed through the osteotomy to fix the position and for an accurate screw positioning (**FIGURE 1**).

1.3 SCREW LENGTH IDENTIFICATION

Determine the appropriate Nexis® MIS screw length using the ruler (**FIGURE 2**).



FIGURE 1

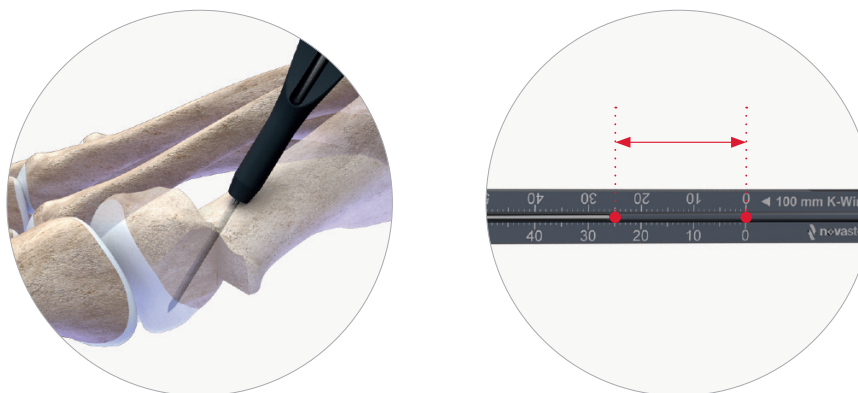

FIGURE 2

1.4 SCREW INSERTION

NOTE: Depending on the bone quality, use the Nexis® MIS countersink Ø 2.8 in order to prepare the screw head room.

Use the Exact2-T8 AO screwdriver tip to insert the Nexis® MIS screw with a power tool or by hand depending on bone quality. Finish the insertion by hand until the screw is flush with the dorsal cortex (**FIGURE 3**).

Once the screw is inserted, it is recommended to check the stability of the osteotomy and the final insertion under fluoroscopy.

Remove the K-Wire.

NOTE: The procedure can also be performed with Nexis® Ø2.3 or Ø2.9 screws and their associated instruments.

Ø2.3 Nexis®

K-wire Ø0.9 lg 80mm
Ruler Lg 80
Countersink Ø2.75
T7 AO screwdriver tip

Ø2.9 Nexis®

K-wire Ø1.0 lg 80mm
Ruler Lg 80
Countersink Ø2.75
T8 AO screwdriver tip

Remove the medial eminence of the first metatarsal bone with an oscillating saw blade.



FIGURE 3

2. MINIMALLY INVASIVE SCARF OSTEOTOMY

2.1 INCISION & EXPOSURE

Perform an incision centered at the exostosis of the first metatarsal. The joint capsule of the first metatarsal is incised according to the surgeon's preference.

2.2 OSTEOTOMY & K-WIRE INSERTION

Perform the mini-invasive Scarf osteotomy thanks to an oscillating saw blade. Once the reduction of M1 deformity is achieved, stabilize the fragments and place a extra-sharp K-wire \varnothing 1.2 through the osteotomy to fix the position and to allow accurate screw positioning (**FIGURE 4**).

NOTE: A Scarf forceps is available on request.

2.3 SCREW LENGTH IDENTIFICATION

Place the ruler over the K-Wire and determine the screw length (**FIGURE 5**).

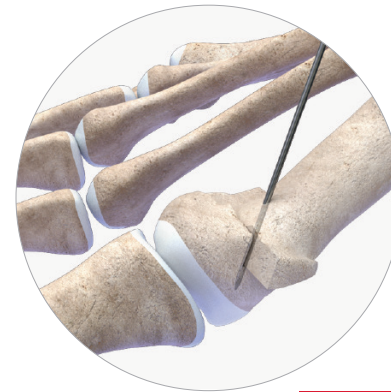

FIGURE 4



FIGURE 5

2.4 SCREW INSERTION

NOTE: Depending on the bone quality, use the Nexis® MIS countersink Ø 2.8 in order to prepare the screw head room.

Use the Exact2-T8 AO screwdriver tip to insert the Nexis® MIS screw with a power tool or by hand depending on bone quality. Finish the insertion by hand until the screw is flush with the dorsal cortex (**FIGURE 6**).

Once the screw is inserted, it is recommended to check the stability of the osteotomy and the final insertion under fluoroscopy.

Remove the K-Wire.

NOTE: The procedure can also be performed with Nexis® Ø2.3 or Ø2.9 screws and their associated instruments.

Ø2.3 Nexis®

K-wire Ø0.9 lg 80mm
Ruler Lg 80
Countersink Ø2.75
T7 AO screwdriver tip

Ø2.9 Nexis®

K-wire Ø1.0 lg 80mm
Ruler Lg 80
Countersink Ø2.75
T8 AO screwdriver tip

Remove the medial eminence of the first metatarsal bone with an oscillating saw blade.



FIGURE 6

3. PHALANGEAL OSTEOTOMY (P1)

3.1 INCISION & EXPOSURE

Realize a medial incision at the metaphyseal junction of the proximal phalanx to expose the first metatarsophalangeal joint.

3.2 OSTEOTOMY & K-WIRE INSERTION

Perform the osteotomy with an oscillating saw blade and perform a varus movement.

Place the extra-sharp K-wire Ø1.2 to fix the position and allow precise placement of the screw (**FIGURE 7**).

3.3 SCREW LENGTH IDENTIFICATION

Before the insertion, determine the screw length using the ruler (**FIGURE 8**).

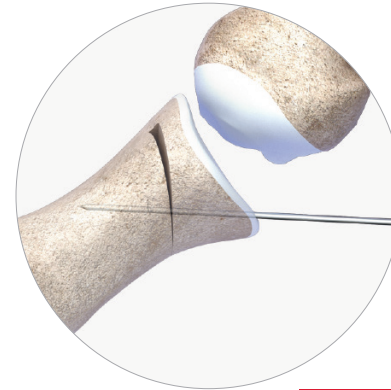

FIGURE 7

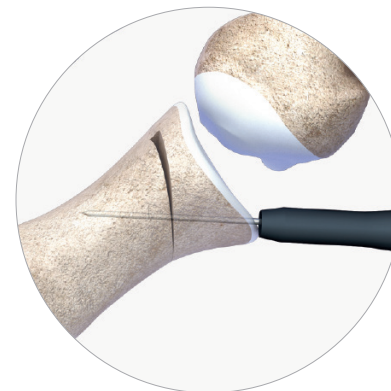

FIGURE 8

3.4 SCREW INSERTION

Use the Exact2-T8 AO screwdriver tip to insert the Nexis® MIS screw with a power tool or by hand depending on bone quality. Finish the insertion by hand until the lateral cortex has been reached (**FIGURE 9**).

Check to ensure proper stability at the osteotomy site.

NOTE: The procedure can also be performed with Nexis® Ø2.3 or Ø2.9 screws and their associated instruments.

Ø2.3 Nexis®

K-wire Ø0.9 lg 80mm
Ruler Lg 80
Countersink Ø2.75
T7 AO screwdriver tip

Ø2.9 Nexis®

K-wire Ø1.0 lg 80mm
Ruler Lg 80
Countersink Ø2.75
T8 AO screwdriver tip



FIGURE 9

OPTIONAL STEPS

PRE-DRILLING

Depending on the surgeon's preference, pre-drilling may be needed. Prepare the bone housing using the cannulated drill-bit over the K-wire before screw insertion.

SCREW LENGTH IDENTIFICATION WITH A DEPTH GAUGE

Depending on the surgeon's preference, pre-drilling may be needed. Prepare the bone housing using the cannulated drill-bit over the K-wire before screw insertion.

4. WEIL OSTEOTOMY

4.1 INCISION & EXPOSURE

Make an incision on the dorsal side of the foot, at the affected MTP joint and dislocate the metatarsal head.

NOTE: A Weil spoon is available on request.

4.2 OSTEOTOMY & K-WIRE INSERTION

Perform the Weil osteotomy with an appropriately sized saw blade. Push back the metatarsal head according to the chosen correction (**FIGURE 10**).

4.3 SCREW INSERTION

The Nexis® Ø2 snap-off screw have been designed to perform faster screw insertion without bone preparation steps.

Insert the screw directly with a wire driver. The snap-off area will break at the end of the insertion. (**FIGURE 11**).

NOTE: In case of a poor bone quality, induce the breakage with a lateral movement.

Remove the medial eminence of the first metatarsal bone with an oscillating saw blade.

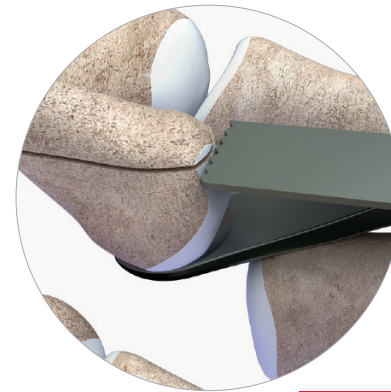

FIGURE 10

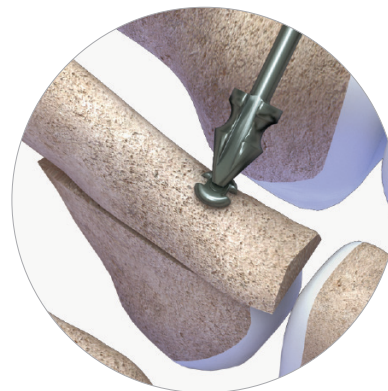

FIGURE 11

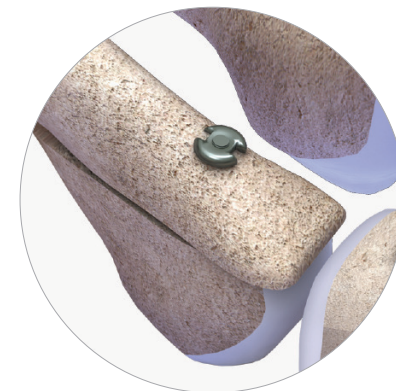

FIGURE 12

Ø2,7MM NEXIS® MIS SCREWS

PART NO.	LENGTH (mm)
SC090014	14
SC090016	16
SC090018	18
SC090020	20
SC090022	22
SC090024	24
SC090026	26
SC090028	28
SC090030	30

Ø1,2MM K-WIRES

PART NO.	DESCRIPTION
-	K-WIRE Ø1,2 LG 80 TR/RD ⁽¹⁾
-	K-WIRE Ø 1,2 LG 100 TR/RD ⁽²⁾
-	K-WIRE Ø 1,2 LG 150 TR/RD ⁽³⁾

⁽¹⁾ K-wire supplied separately - Medetechnik® K-wire (33-T10-R-12-080) or Novastep® K-wire (CKW01017) are available depending on your market.

⁽²⁾ K-wire supplied separately - Medetechnik® K-wire (33-T10-R-12-100) or Novastep® K-wire (CKW01014) are available depending on your market.

⁽³⁾ K-wire supplied separately - Medetechnik® K-wire (33-T10-R-12-150) or Novastep® K-wire (CKW01015) are available depending on your market.

SNAP-OFF SCREWS

LENGTH (MM)	Ø2 mm
11	SC040011
12	SC040012
13	SC040013
14	SC040014
15	SC040015
16	SC040016

K-WIRES

PART NO.	DESCRIPTION
-	K-WIRE Ø0,9 LG 80 TR/RD ⁽¹⁾
-	K-WIRE Ø 1,0 LG 80 TR/RD ⁽²⁾
-	K-WIRE Ø 1,4 LG 100 TR/RD ⁽³⁾

⁽¹⁾K-wire supplied separately - Medetechnik® K-wire (33-T10-R-09-080) or Novastep® K-wire (CKW01009) are available depending on your market.

⁽²⁾K-wire supplied separately - Medetechnik® K-wire (33-T10-R-10-080) or Novastep® K-wire (CKW01016) are available depending on your market.

⁽³⁾K-wire supplied separately - Medetechnik® K-wire (33-T10-R-14-100) or Novastep® K-wire (CKW01002) are available depending on your market.

COMPRESSIVE SCREWS

LENGTH (MM)	Ø2.3 mm	Ø2.9 mm	Ø4MM
10	SC010010	SC020010	-
12	SC010012	SC020012	-
14	SC010014	SC020014	-
16	SC010016	SC020016	-
18	SC010018	SC020018	SC050018
20	SC010020	SC020020	SC050020
22	SC010022	SC020022	SC050022
24	SC010024	SC020024	SC050024
26	SC010026	SC020026	SC050026
28	SC010028	SC020028	SC050028
30	SC010030	SC020030	SC050030
32	-	SC020032	SC050032
34	-	SC020034	SC050034
36	-	-	SC050036
38	-	-	SC050038
40	-	-	SC050040
42	-	-	SC050042
44	-	-	SC050044
46	-	-	SC050046
48	-	-	SC050048
50	-	-	SC050050
55	-	-	SC050055
60	-	-	SC050060

INSTRUMENTATION

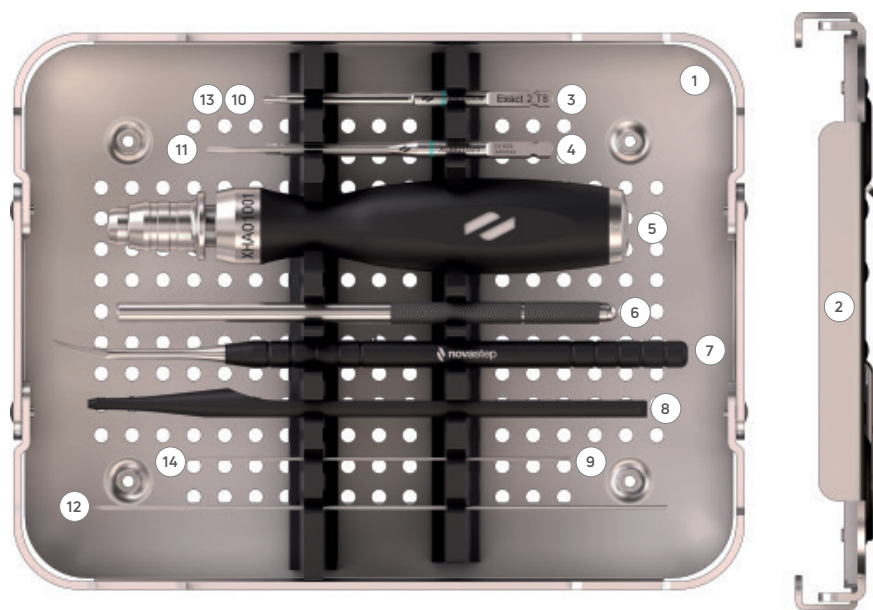

NEXIS® MIS INSTRUMENTATION

#	DESCRIPTION	PART NO.	QTY
1	TRAY	ACC1018P0001	1
2	LID	ACC1018P0002	1
3	EXACT2-T8 SCREWDRIVER TIP	XSD02006	2
4	COUNTERSINK Ø 2,8	XRE01024	1
5	AO HANDLE	XHA01001	1
6	FINE SURGICAL HANDLE ⁽¹⁾	-	1
7	PERIOESTAL ELEVATOR SINGLE TIP	XMS01011	1
8	RULER LG 100/150	XGA01013	1
9	K-WIRE Ø1,2 LG 100 TR/RD ⁽²⁾	-	5

⁽¹⁾ Reference SF13 supplied separately - availability depending on your market.

OPTIONAL - NEXIS® MIS INSTRUMENTATION

#	DESCRIPTION	PART NO.	QTY
10	REMOVAL EXACT2-T8 AO SCREWDRIVER TIP	XSD02007	1
11	CANNULATED DRILL BIT Ø1,9	XDB01025	1
12	K-WIRE Ø1,2 LG 150 TR/RD ⁽³⁾	-	5

⁽⁴⁾ K-wire supplied separately - Medetechnik® K-wire (33-T10-R-12-150) or Novastep® K-wire (CKW01015) are available depending on your market.

OPTIONAL NEXIS® Ø2,3 INSTRUMENTATION

#	DESIGNATION	REFERENCE	QTY
13	T7 AO SCREWDRIVER TIP	XSD01001	2
14	K-WIRE Ø0,9 LG 100 TR/RD ⁽⁴⁾	-	5

⁽⁵⁾ K-wire supplied separately - Medetechnik® K-wire (33-T10-R-09-100) or Novastep® K-wire (CKW01008) are available depending on your market.

FOREFOOTCOMPLETE TRAY

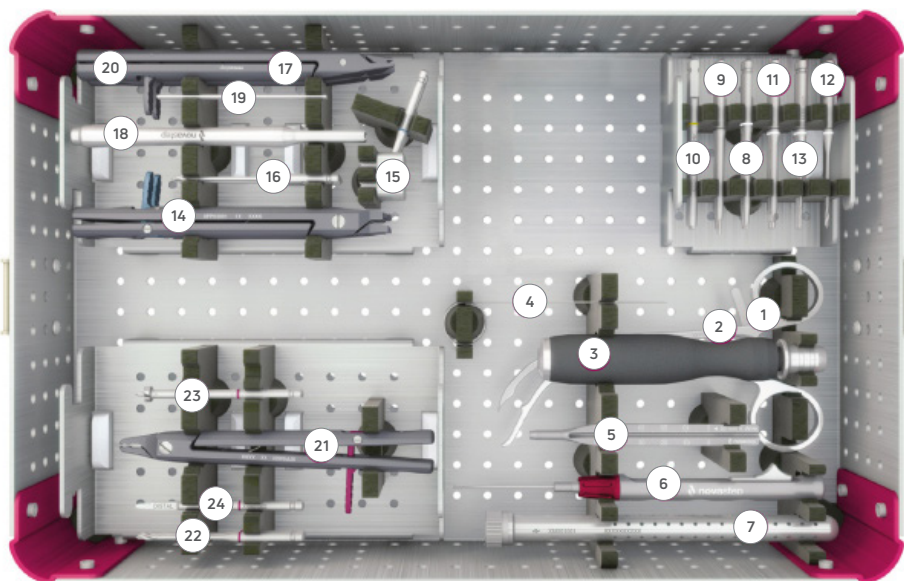

UNIVERSAL INSTRUMENTATION

#	DESCRIPTION	PART NO.	QTY
-	TRAY	ACC1001P0001	1
-	LID	ACC1001P0002	1
1	SCARF FORCEPS**	XFP01001	1
2	CHEVRON FORCEPS**	XFP01004	1
3	AO HANDLE	XHA01001	1
4	CLEANING PIN Ø 0.9	XKW01001	1
5	RULER LG 80	XGA01001	1
6	DEPTH GAUGE	XGA01002	1
7	K-WIRE TUBE ⁽¹⁾⁽²⁾⁽³⁾	XMS01001	1

Ø2, Ø2.3, Ø2.9 NEXIS® MODULE

#	DESCRIPTION	PART NO.	QTY
-	MODULE	ACC1001P0006	1
8	T7 AO SCREWDRIVER TIP	XSD01001	2
9	T8 AO SCREWDRIVER TIP	XSD02001	2
10	SNAP-OFF AO SCREWDRIVER TIP	XSD03001	1
11	COUNTERSINK Ø 2.75	XRE01001	1
12	SOLID DRILL BIT Ø 1.75	XDB02001	1
13	CANNULATED DRILL BIT Ø 1.75	XDB01001	1

ARCAD® FOREFOOT MODULE

#	DESCRIPTION	PART NO.	QTY
-	MODULE	ACC1001P0003	1
14	ARCAD® 10 - FORCEPS	XFP03001	1
15	ARCAD® 10 - DRILL GUIDE	XDG01001	1
16	DRILL BIT Ø 2	XDB01008	1
17	ANGLED STAPLES FORCEPS	XFP02001	1
18	IMPACTOR	XMS01002	1
19	POSITIONING PIN Ø 2	XPP01001	2
20	STRAIGHT STAPLES - FORCEPS	XFP05001	1

LYNC® MODULE

#	DESCRIPTION	PART NO.	QTY
-	MODULE	ACC1001P0004	1
21	FORCEPS	XFP04001	1
22	DRILL BIT Ø 2.3	XDB01003	1
23	SURFACING REAMER	XRE01002	1
24	RASP	XRA01002	1

⁽¹⁾K-wire supplied separately - Medetechnik® K-wire (33-T10-R-09-080) or Novastep® K-wire (CKW01009) are available depending on your market.

⁽²⁾K-wire supplied separately - Medetechnik® K-wire (33-T10-R-10-080) or Novastep® K-wire (CKW01016) are available depending on your market.

⁽³⁾K-wire supplied separately - Medetechnik® K-wire (33-T10-R-14-100) or Novastep® K-wire (CKW01002) are available depending on your market.

* Optional

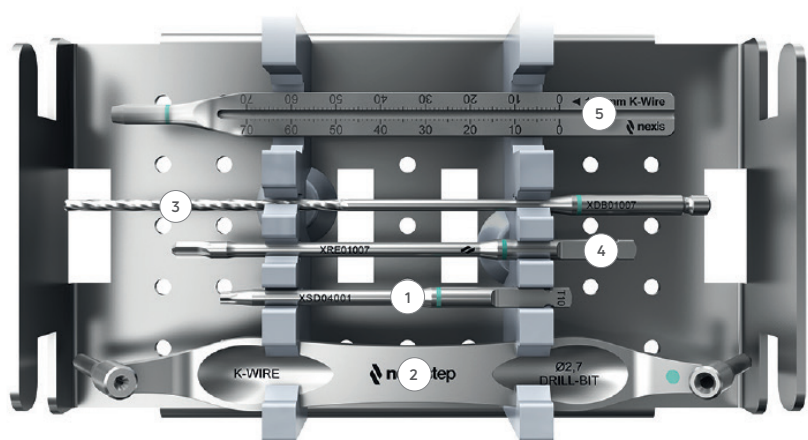

Ø4 NEXIS® MODULE

#	DESCRIPTION	PART NO.	QTY
-	MODULE	ACC1002P0004	1
1	T10 AO SCREWDRIVER TIP	XSD04001	1
2	DOUBLE DRILL GUIDE FOR SCREW Ø 4	XDG01009	1
3	CANNULATED DRILL BIT Ø 2.7	XDB01007	1
4	COUNTERSINK Ø 3.7	XRE01007	1
5	RULER LG 100	XGA01004	1

FOREFOOTEXACT TRAY

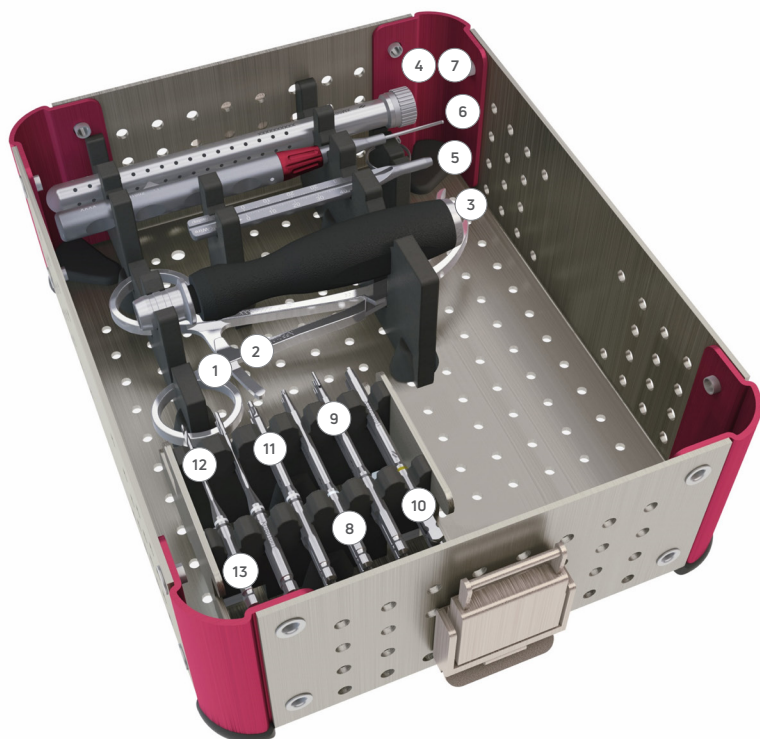

UNIVERSAL INSTRUMENTATION

#	DESCRIPTION	PART NO.	QTY
-	TRAY	ACC1001P0001	1
-	LID	ACC1001P0002	1
1	SCARF FORCEPS**	XFP01001	1
2	CHEVRON FORCEPS**	XFP01004	1
3	AO HANDLE	XHA01001	1
4	CLEANING PIN Ø 0.9	XKW01001	1
5	RULER LG 80	XGA01001	1
6	DEPTH GAUGE	XGA01002	1
7	K-WIRE TUBE ⁽¹⁾⁽²⁾⁽³⁾	XMS01001	1

NEXIS® MODULE Ø2, Ø2.3, Ø2.9

#	DESCRIPTION	PART NO.	QTY
-	MODULE	ACC1001P0006	1
8	T7 AO SCREWDRIVER TIP	XSD01001	1
9	T8 AO SCREWDRIVER TIP	XSD02001	1
10	SNAP-OFF AO SCREWDRIVER TIP	XSD03001	1
11	COUNTERSINK Ø 2.75	XRE01001	1
12	SOLID DRILL BIT Ø 1.75	XDB02001	1
13	CANNULATED DRILL BIT Ø 1.75	XDB01001	1

⁽¹⁾K-wire supplied separately - Medetechnik® K-wire (33-T10-R-09-080) or Novastep® K-wire (CKW01009) are available depending on your market.

⁽²⁾K-wire supplied separately - Medetechnik® K-wire (33-T10-R-10-080) or Novastep® K-wire (CKW01016) are available depending on your market.

⁽³⁾K-wire supplied separately - Medetechnik® K-wire (33-T10-R-14-100) or Novastep® K-wire (CKW01002) are available depending on your market.

* Optional

enovis.

T +33 (0) 2 99 33 86 50 F +33 (0) 9 70 29 18 95

Legal manufacturer: Novastep® S.A.S
2 Allée Jacques Frimot | 35000 Rennes | France
contact-intfa@enovis.com
www.int.novastep.life
Copyright © 2024 Enovis Foot and Ankle

Carefully read the enclosed Instructions For Use (IFU) and all packaging label information. Devices: Implants: Class IIb-CE1639 / Instruments: Class I / Class Ir-CE1639 / Class IIa-CE1639.

REFERENCE: NEX-FORE-ST-ED5-02-26-EN