

nexis[®]
Cannulated Screws



OPERATIVE TECHNIQUE

FOREFOOT

Nexis[®] MIS Ø 2.7: beveled compressive screws

Nexis[®] Ø 2 / Ø 2.3 / Ø 2.9 / Ø 4: compressive screws & snap-off screws



- . Complete & versatile range
- . Self-drilling & Self-tapping
- . Comprehensive & modular instrumentation

*Creating
Better
Together™*

nexis[®] nexis[®] | MIS

Table of contents

Introduction

- 02** Indications & Contraindications
- 02** Examples of use

Design Features

- 03** 1 - Nexis[®] MIS Ø 2.7
- 04** 2 - Nexis[®] MIS instrumentation
- 05** 3 - Nexis[®] Ø 2 / Ø 2.3 / Ø 2.9 / Ø 4
- 06** 4 - Nexis[®] instrumentation

Surgical Technique

- 07** 1 - Chevron osteotomy
- 09** 2 - Mini-invasive Scarf osteotomy
- 11** 3 - P1 osteotomy
- 13** 4 - Weil osteotomy

References

- 14** 1 - Nexis[®] MIS Ø 2.7
- 14** 2 - Nexis[®] Ø 2 / Ø 2.3 / Ø 2.9 / Ø 4
- 15** 3 - Nexis[®] MIS instrumentation
- 16** 4 - Nexis[®] instrumentation

Introduction

Indications & Contraindications

Indications

The osteosynthesis screws are indicated for arthrosis, hallux valgus and other bone alignment defaults (pes cavus, flatfoot, malalignment secondary to previous trauma).

Note: Detailed information on each medical device is provided in the instruction for use. Refer to the instruction for use for a complete list of side effects, warnings, precautions for use and directions for use.

Contraindications

- Severe muscular, neurological or vascular deficiency in the extremity concerned.
- Bone destruction or poor bone quality, likely to impair implant stability.
- Hypersensitivity to vanadium and/or aluminium.

Examples of use



Snap-off Ø 2 mm:
Weil osteotomy.



**MIS Ø 2.7 mm
Ø 2.3 & Ø 2.9 mm:**
Scarf & Chevron Osteotomies,
P1 osteotomy.



Ø 4 mm:
MTP & Cuneo-metatarsal
arthrodesis.



Design Features

1 - Nexis® MIS Ø 2.7

1 Cannulated screw: *Extra-Sharp* Ø 1.2 K-Wire

2 Elliptic beveled head

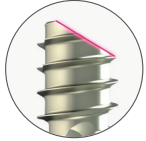

Bevel (30°):
Maximization of cortical anchorage and preservation of soft tissue

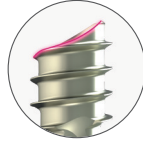

Elliptic bevel:
Allows for additional angular rotation to preserve the burial of the head



3 **Exact2-T Recess**
Specific & universal

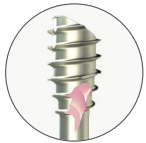

4 **Positive locking channels**



5 **Self-drilling & self-tapping**

- Penetrating sharp tips
- Facilitated insertion

6 **Deep dual thread**
• Maximized anchorage & compression

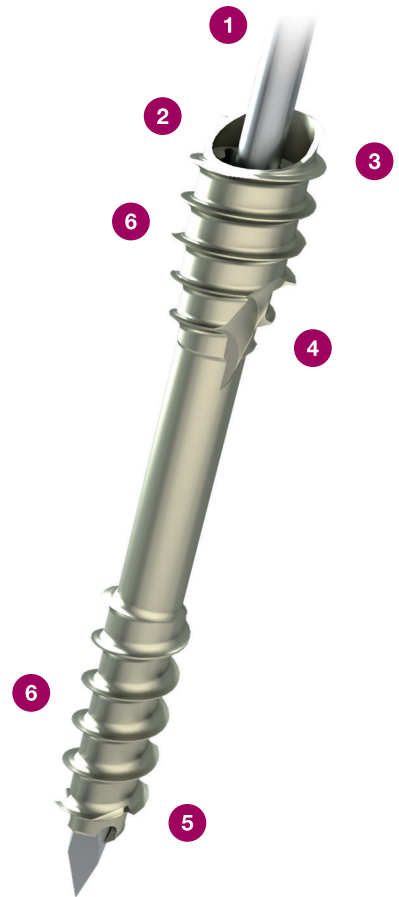

Optimized range
Screws available in lengths
of 14 to 30 mm

Design Features

2 - Nexis® MIS instrumentation

Extra-Sharp Ø 1.2 K-Wire

Ø 1.2 mm: provides greater stiffness*
Sharpened tip: allows for angulated insertion



Exact2-T8 AO screwdriver tip

Exact2-T8 recess:

- . **Specific:** easy indexing of the Exact2-T8 AO screwdriver tip
- . **Universal:** possible removal with standard instrumentation



Exact2-T8 recess ensures the unique positioning of the screwdriver tip.

The laser marking and bevel of the Exact2-T8 AO screwdriver tip facilitate the proper placement of the screw head.



*Greater stiffness than a Ø0.9 k-wire

Nexis® MIS Mini Tray

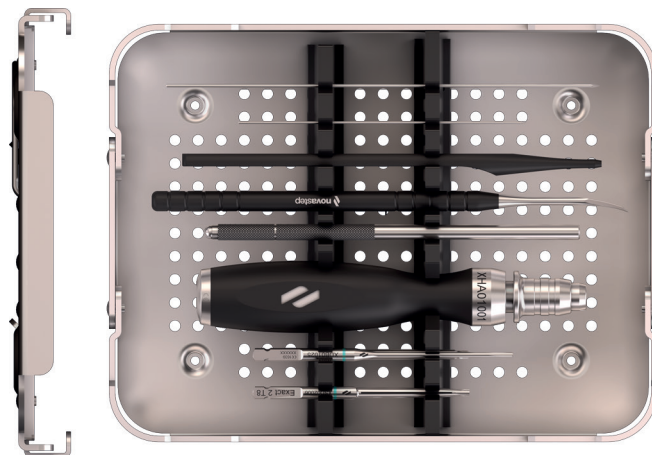



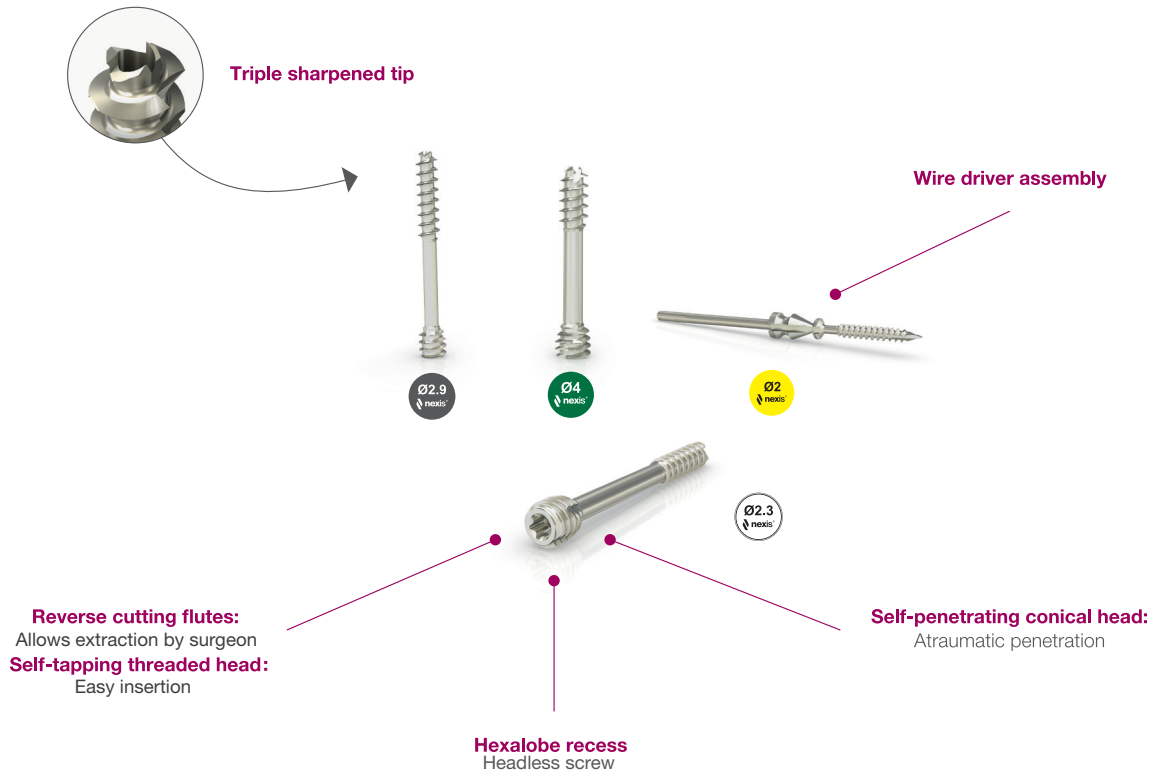

Extra-sharp K-wire & Exact2-T8 AO screwdriver tip: optional in the **Nexis® ForefootCOMPLETE & ForefootEXACT** trays

Design Features

3 - Nexis® Ø 2 / Ø 2.3 / Ø 2.9 / Ø 4s



				
	Weil	T7	T8	T10
Screwdriver tip	Weil	T7	T8	T10
Distal thread diameter	Ø 2 mm	Ø 2.3 mm	Ø 2.9 mm	Ø 4mm
Length	11 - 16 mm ⁽¹⁾	10 - 30 mm ⁽²⁾	10 - 34 mm ⁽²⁾	18 - 60 mm ⁽³⁾
K-wire	N/A	Ø 0.9 x 80 mm	Ø 1.0 x 80 mm	Ø 1.4 x 100 mm
Screwdriver	N/A	Self-retaining / Non self-retaining ⁽⁴⁾	Self-retaining / Non self-retaining ⁽⁴⁾	Self-retaining

⁽¹⁾ 1 mm increments. / ⁽²⁾ 2 mm increments. / ⁽³⁾ 2 mm increments up to 50 mm, then 5 mm increments. / ⁽⁴⁾ Optional.

Design Features

4 - Nexis® instrumentation

Modularity

A modular concept allowing customization of the ancillary according to the preferences of the practitioner or the indication. Two versions available:

- **ForefootCOMPLETE:** possibility of accommodating Nexis® screw, Arcad® staple and Lync® intramedullary implant modules in a complete tray.
- **ForefootEXACT:** possibility of interchanging the modules Nexis®, Arcad® staple and Lync® intramedullary implant for space saving in a half-tray.

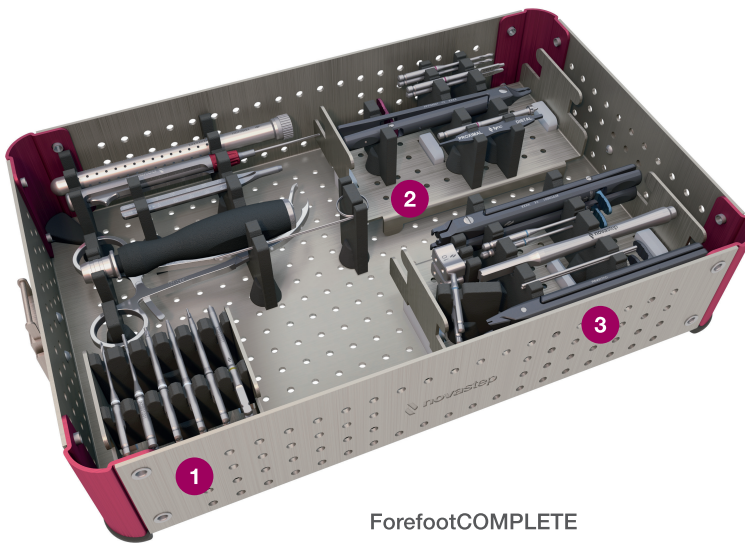

ForefootCOMPLETE

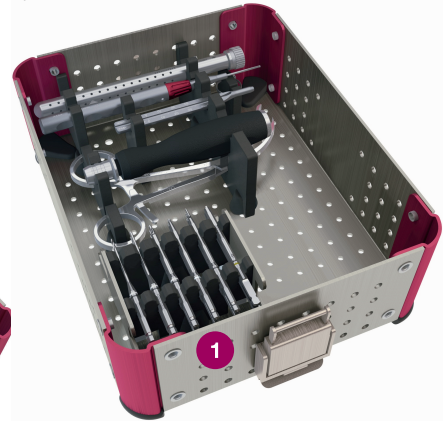

ForefootEXACT

- ① Nexis® screw module
- ② Lync® intramedullary implant module
- ③ Arcad® staple module

Dedicated instrumentation

Dedicated instrumentation for each osteotomy: Weil, Scarf, Chevron, M1.

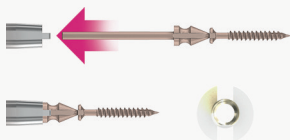

Snap-off AO screwdriver tip:
Snap-off screws compatible for use with wire driver or for manual fixation with specific snap-off screwdriver tip.



Spoon for Weil osteotomy
(XMS01007)*

* Optional



Scarf forceps
(XFP01001)*



Chevron forceps
(XFP01004)*

Color code identification

Color coded equipment permits at-a-glance instrument identification.

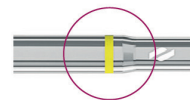

● : Ø 2 mm

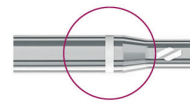

○ : Ø 2.3 mm

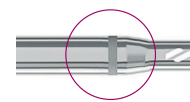

● : Ø 2.9 mm

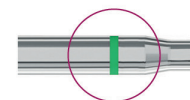

● : Ø 4 mm

Surgical Technique

Novastep® does not practice medicine and does not recommend this or any other surgical technique. Each surgeon must consider the specific needs of each patient and is responsible for making applicable adjustment and determining and using the appropriate technique for implanting the device in each cases.

1 - Chevron Osteotomy

1.1 - Incision & exposure

A medial incision is performed (2 to 3 cm) for first metatarsal-phalangeal joint exposure. The first metatarsal-phalangeal joint capsule is incised according to the surgeon's preference to expose the first metatarsal medial eminence.

1.2 - Osteotomy & K-Wire insertion

Perform the Chevron Osteotomy with an oscillating saw blade. When reduction is achieved, stabilize the two bone fragments with a *extra-sharp* K-wire Ø 1.2 mm placed through the osteotomy to fix the position and for an accurate screw positioning.



1.3 - Screw length identification

Determine the appropriate Nexis® MIS screw length using the ruler.

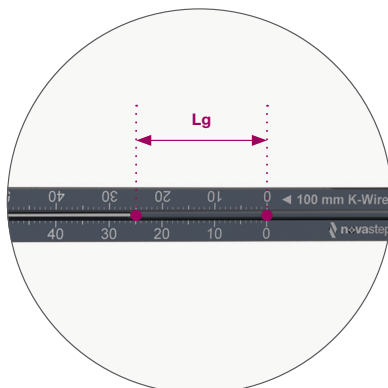

Surgical Technique

1.4 - Screw insertion

Option: Depending on the bone quality, use the Nexis® MIS countersink Ø 2.8 in order to prepare the screw head room.

Use the Exact2-T8 AO screwdriver tip to insert the Nexis® MIS screw with a power tool or by hand until the screw is flush with the dorsal cortex.

Once the screw is inserted, it is recommended to check the stability of the osteotomy and the final insertion under fluoroscopy.
Remove the K-Wire.



Option: The procedure can also be performed with Nexis® Ø 2.3 or Ø 2.9 screws and their associated instruments:



K-wire Ø 0.9 lg 80 mm
Ruler Lg 80
Countersink Ø 2.75
T7 AO screwdriver tip



K-wire Ø 1.0 lg 80 mm
Ruler Lg 80
Countersink Ø 2.75
T8 AO screwdriver tip

Remove the medial eminence of the first metatarsal bone with an oscillating saw blade.

Surgical Technique

2 - Mini-invasive Scarf osteotomy

2.1 - Incision & exposure

Perform an incision centered at the exostosis of the first metatarsal. The joint capsule of the first metatarsal is incised according to the surgeon's preference.

2.2 - Osteotomy & K-Wire insertion

Perform the mini-invasive Scarf osteotomy thanks to an oscillating saw blade. Once the reduction of M1 deformity is achieved, stabilize the fragments and place a *extra-sharp* K-wire $\text{\O} 1.2$ through the osteotomy to fix the position and to allow accurate screw positioning.

Option: A Scarf forceps is available on request.

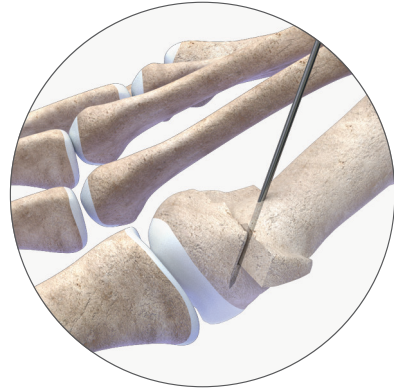

2.3 - Screw length identification

Place the ruler over the K-Wire and determine the screw length.

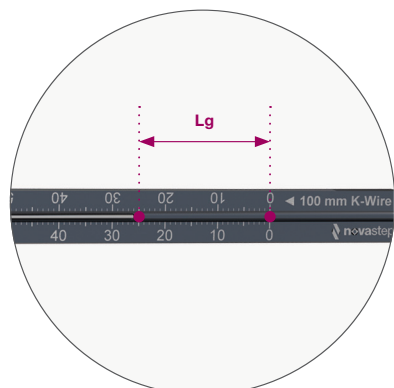

Surgical Technique

2.4 - Screws insertion

Option: Depending on the bone quality, use the Nexis® MIS countersink Ø 2.8 in order to prepare the screw head room.

Use the Exact2-T8 AO screwdriver tip to insert the Nexis® MIS screw with a power tool or by hand until the screw is flush with the dorsal cortex.

Once the screw is inserted, it is recommended to check the stability of the osteotomy and the final insertion under fluoroscopy.

Remove the K-Wire.



Option: The procedure can also be performed with Nexis® Ø 2.3 or Ø 2.9 screws and their associated instruments:



K-wire Ø 0.9 lg 80 mm
Ruler Lg 80
Countersink Ø 2.75
T7 AO screwdriver tip



K-wire Ø 1.0 lg 80 mm
Ruler Lg 80
Countersink Ø 2.75
T8 AO screwdriver tip

Remove the medial eminence of the first metatarsal bone with an oscillating saw blade.

Surgical Technique

3 - Phalangeal Osteotomy (P1)

3.1 - Incision & exposure

Realize a medial incision at the metaphyseal junction of the proximal phalanx to expose the first metatarsophalangeal joint.

3.2 - Osteotomy & K-wire insertion

Perform the osteotomy with an oscillating saw blade and perform a varus movement.

Place the *extra-sharp* K-wire Ø 1.2 to fix the position and allow precise placement of the screw.

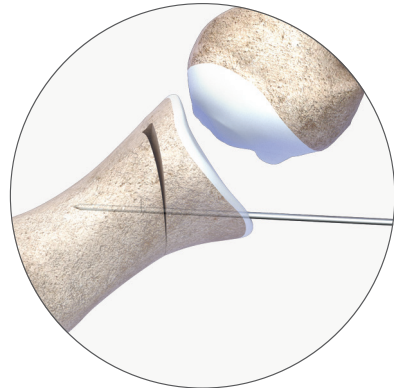

3.3 - Screw length identification

Before the insertion, determine the screw length using the ruler.

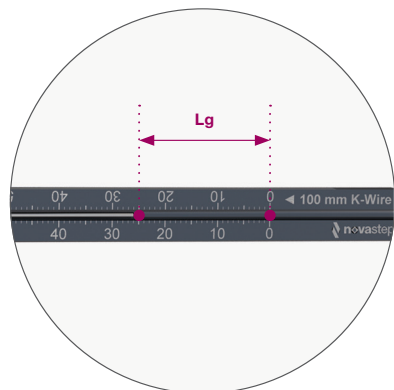
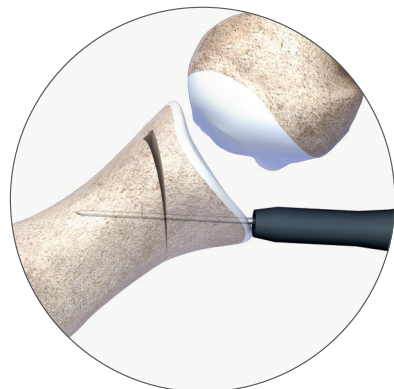

Surgical Technique

3.4 - Screw insertion

Use the Exact2-T8 AO screwdriver tip to insert the Nexis® MIS screw with a power tool or by hand until the lateral cortex has been reached. Check to ensure proper stability at the osteotomy site.



Option: The procedure can also be performed with Nexis® Ø 2.3 or Ø 2.9 screws and their associated instruments:



K-wire Ø 0.9 lg 80 mm
Ruler Lg 80
Countersink Ø 2.75
T7 AO screwdriver tip



K-wire Ø 1.0 lg 80 mm
Ruler Lg 80
Countersink Ø 2.75
T8 AO screwdriver tip

Optional steps

Pre-drilling:

Depending on the surgeon's preference, pre-drilling may be needed. Prepare the bone housing using the cannulated drill-bit⁽¹⁾ over the K-wire before screw insertion.

⁽¹⁾ A solid drill-bit is also available.



Screw length identification with a depth gauge:

After bone preparation and K-wire removal, a depth gauge is available to determine the screw length.



Surgical Technique

4 - Weil Osteotomy

4.1 - Incision & exposure

Make an incision on the dorsal side of the foot, at the affected MTP joint and dislocate the metatarsal head.

Option: A Weil spoon is available on request.

4.2 - Osteotomy & K-wires insertion

Perform the Weil osteotomy with an appropriately sized saw blade. Push back the metatarsal head according to the chosen correction.

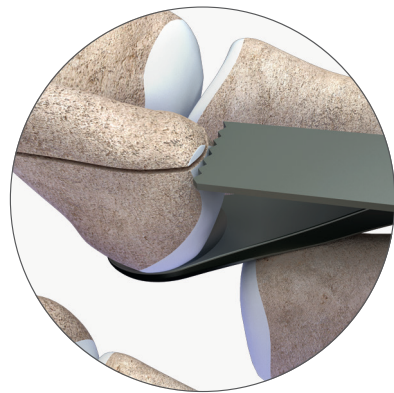

4.3 - Screw insertion

The Nexis® Ø2 snap-off screw have been designed to perform faster screw insertion without bone preparation steps.

Insert the screw directly with a wire driver. The snap-off area will break at the end of the insertion.

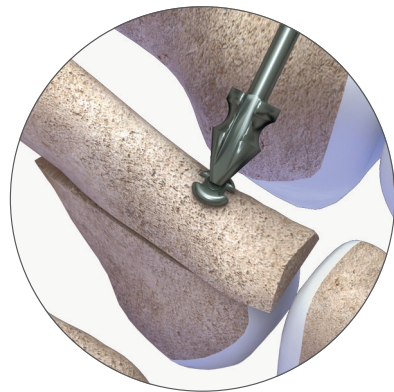

Note: In case of a poor bone quality, induce the breakage with a lateral movement.

If necessary, use the Weil screwdriver tip in order to complete the burying of the screw head. Check the stability of the osteotomy.

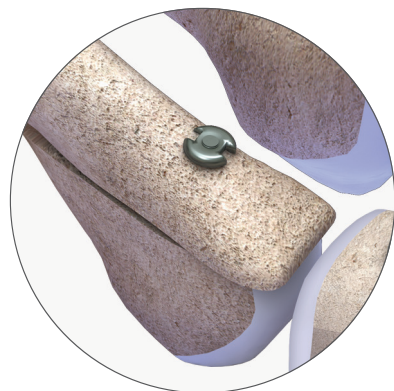

References

1 - Nexis® MIS Ø 2.7

Nexis® MIS screws



Length (mm)	Reference
14 mm	SC090014
16 mm	SC090016
18 mm	SC090018
20 mm	SC090020
22 mm	SC090022
24 mm	SC090024
26 mm	SC090026
28 mm	SC090028
30 mm	SC090030

K-Wire Ø 1.2 mm

Description	Reference
K-Wire Ø 1.2 Ig 80 TR/RD *	CKW01017 ⁽¹⁾
K-Wire Ø 1.2 Ig 100 TR/RD	CKW01014 ⁽²⁾
K-Wire Ø 1.2 Ig 150 TR/RD **	CKW01015 ⁽³⁾

⁽¹⁾ Medetechnik® K-wire (33-T10-R-12-080) is also available depending on your market.
⁽²⁾ Medetechnik® K-wire (33-T10-R-12-100) is also available depending on your market.
⁽³⁾ Medetechnik® K-wire (33-T10-R-12-150) is also available depending on your market.

* *Optional in the ForefootCOMPLETE*
 ** *Optional in the Nexis® MIS Mini tray*

2 - Nexis® Ø 2 / Ø 2.3 / Ø 2.9 / Ø 4

Snap-off screws



Length (mm)	Ø 2 mm
11	SC040011
12	SC040012
13	SC040013
14	SC040014
15	SC040015
16	SC040016

Compressive screws



Length (mm)	Ø 2.3 mm	Ø 2.9 mm	Ø 4 mm
10	SC010010	SC020010	-
12	SC010012	SC020012	-
14	SC010014	SC020014	-
16	SC010016	SC020016	-
18	SC010018	SC020018	SC050018
20	SC010020	SC020020	SC050020
22	SC010022	SC020022	SC050022
24	SC010024	SC020024	SC050024
26	SC010026	SC020026	SC050026
28	SC010028	SC020028	SC050028
30	SC010030	SC020030	SC050030
32	-	SC020032	SC050032
34	-	SC020034	SC050034
36	-	-	SC050036
38	-	-	SC050038
40	-	-	SC050040
50	-	-	SC050050
55	-	-	SC050055
60	-	-	SC050060

K-Wires

Ref	Description
CKW01009 ⁽¹⁾	K-Wire Ø 0.9 Lg 80 TR/RD
CKW01016 ⁽²⁾	K-Wire Ø 1.0 Lg 80 TR/RD
CKW01002 ⁽³⁾	K-Wire Ø 1.4 Lg 100 TR/RD

⁽¹⁾ Medetechnik® K-wire (33-T10-R-09-080) is also available depending on your market.

⁽²⁾ Medetechnik® K-wire (33-T10-R-10-080) is also available depending on your market.

⁽³⁾ Medetechnik® K-wire (33-T10-R-14-100) is also available depending on your market.

References

3 - Nexis® MIS instrumentation

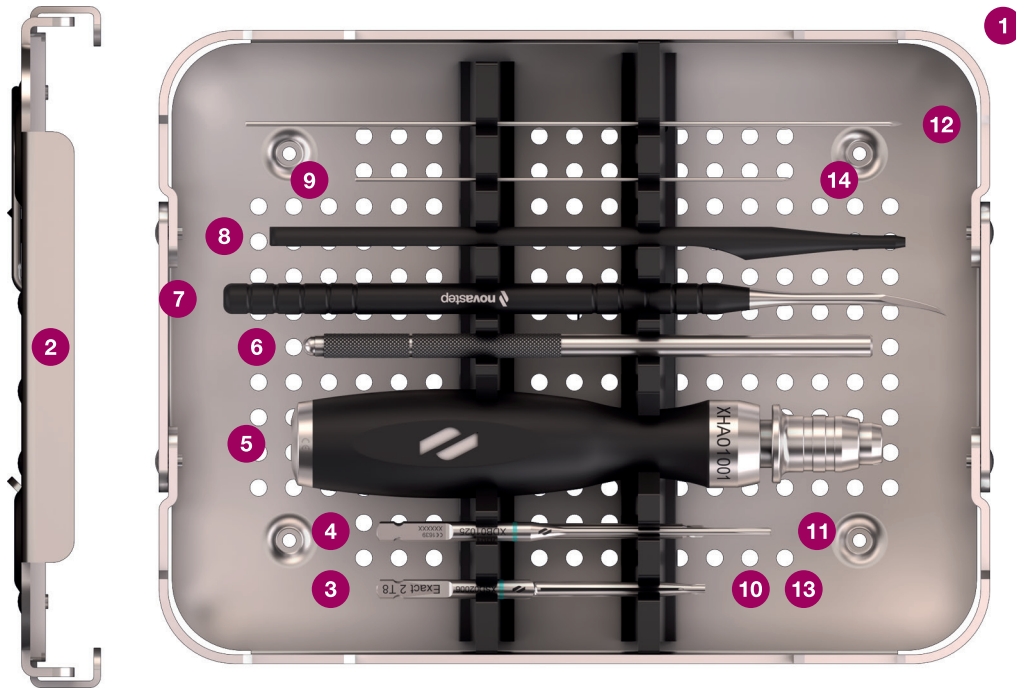

Nexis® MIS instrumentation

Number	Ref	Description	Qty
1	ACC1018P0001	Tray	1
2	ACC1018P0002	Lid	1
3	XSD02006	Exact-2 T8 AO screwdriver tip	2
4	XRE01024	Countersink Ø 2.8	1
5	XHA01001	AO handle	1
6	-	Fine surgical handle ⁽¹⁾	1
7	XMS01011	Periosteal elevator single tip	1
8	XGA01013	Ruler Lg 100/150	1
9	-	K-wire Ø 1.2 Lg 100 TR/RD ⁽²⁾	5

⁽¹⁾Reference SF13 supplied separately - availability depending on your market

⁽²⁾K-wire supplied separately - Medetechnik® K-wire (33-T10-R-12-100) or Novastep® K-wire (CKW01014) are available depending on your market.

Optional - Nexis® MIS instrumentation

Number	Ref	Description	Qty
10	XSD02007	Removal Exact-2 T8 AO screwdriver tip	1
11	XDB01025	Cannulated drill bit Ø 1.9	1
12	-	K-wire Ø 1.2 Lg 150 TR/RD ⁽³⁾	5

⁽³⁾K-wire supplied separately - Medetechnik® K-wire (33-T10-R-12-150) or Novastep® K-wire (CKW01015) are available depending on your market.

Optional - Nexis® Ø 2.3 instrumentation

Number	Ref	Description	Qty
13	XSD01001	T7 AO screwdriver tip	2
14	-	K-wire Ø 0.9 Lg 100 TR/RD ⁽⁴⁾	5

⁽⁴⁾K-wire supplied separately - Medetechnik® K-wire (33-T10-R-09-100) or Novastep® K-wire (CKW01008) are available depending on your market.

References

4 - Nexis® instrumentation

1 - ForefootCOMPLETE Tray

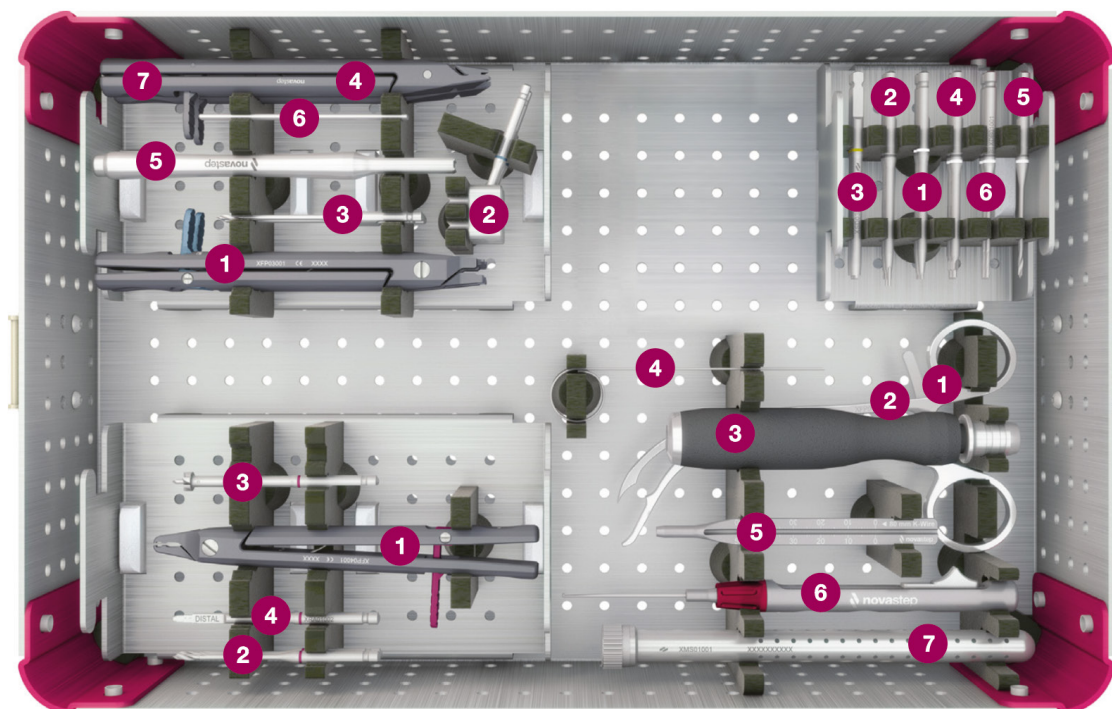

Universal instruments

Number	Ref	Description	Qty
	ACC1001P0001	Forefoot complete tray	1
	ACC1001P0002	Forefoot complete Lid	1
1	XFP01001	Scarf Forceps **	1
2	XFP01004	Chevron Forceps **	1
3	XHA01001	AO Handle	1
4	XKW01001	Cleaning pin Ø 0.9	1
5	XGA01001	Ruler Lg 80	1
6	XGA01002	Depth gauge	1
7	XMS01001	K-wire tube	1
-	-	K-wire Ø0.9 lg 80 TR/RD ⁽¹⁾	1
-	-	K-wire Ø1.0 lg 80 TR/RD ⁽²⁾	1
-	-	K-wire Ø1.4 lg 100 TR/RD ⁽³⁾	1

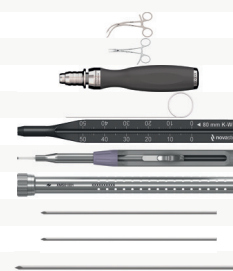

⁽¹⁾K-wire supplied separately - Medetechnik® K-wire (33-T10-R-09-080) or Novastep® K-wire (CKW01009) are available depending on your market.

⁽²⁾K-wire supplied separately - Medetechnik® K-wire (33-T10-R-10-080) or Novastep® K-wire (CKW01006) are available depending on your market.

⁽³⁾K-wire supplied separately - Medetechnik® K-wire (33-T10-R-14-100) or Novastep® K-wire (CKW01002) are available depending on your market.

**Optional

Nexis® module Ø 2, 2.3 & 2.9

Number	Ref	Description	Qty
	ACC1001P0006	Module	1
1	XSD01001	T7 AO screwdriver tip	1
2	XSD02001	T8 AO screwdriver tip	1
3	XSD03001	Snap-off AO screwdriver tip	1
4	XRE01001	Countersink Ø 2.75	1
5	XDB02001	Solid drill bit Ø 1.75	1
6	XDB01001	Cannulated drill bit Ø 1.75	1



References

Arcad® forefoot module

Number	Ref	Description	Qty
	ACC1001P0003	Module	1
1	XFP03001	Arcad® 10 - Forceps	1
2	XDG01001	Arcad® 10 - Drill-guide	1
3	XDB01008	Drill bit Ø 2	1
4	XFP02001	Angled staples Forceps	1
5	XMS01002	Impactor	1
6	XPP01001	Positioning pin Ø 2	2
7	XFP05001	Straight staples Forceps	1



Lync® module

Number	Ref	Description	Qty
	ACC1001P0004	Module	1
1	XFP04001	Forceps	1
2	XDB01003	Drill bit Ø 2.3	1
3	XRE01002	Surfacing reamer	1
4	XRA01002	Rasp	1



2 - Optional - Nexis® Ø 4 module

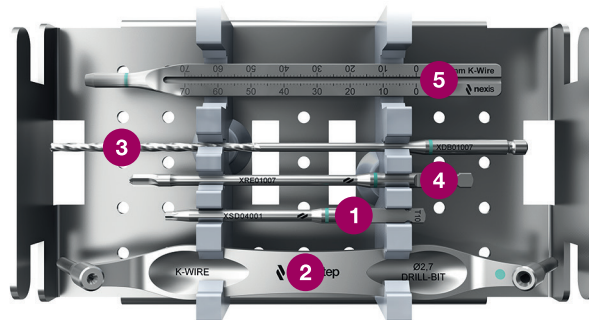

Nexis® Ø 4 module

Number	Ref	Description	Qty
	ACC1002P0004	Module	1
1	XSD04001	T10 AO screwdriver tip	1
2	XDG01009	Double drill guide for screw Ø 4.0	1
3	XDB01007	Cannulated drill bit Ø 2.7	1
4	XRE01007	Nexis® / PECA®-C - Countersink Ø 3.7	1
5	XGA01004	Ruler Lg 100	1

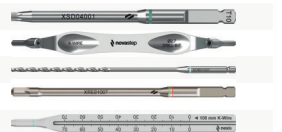

References

3 - ForefootEXACT Tray



Universal instruments

Number	Ref	Description	Qty
	ACC1001P0008	Forefoot exact tray	1
	ACC1001P0007	Forefoot exact Lid	1
1	XFP01001	Scarf Forceps **	1
2	XFP01004	Chevron Forceps **	1
3	XHA01001	AO handle	1
4	XKW01001	Cleaning pin Ø 0.9	1
5	XGA01001	Ruler Lg 80	1
6	XGA01002	Depth gauge	1
7	XMS01001	K-wire tube	1
-	-	K-wire Ø0.9 lg 80 TR/RD ⁽¹⁾	1
-	-	K-wire Ø1.0 lg 80 TR/RD ⁽²⁾	1
-	-	K-wire Ø1.4 lg 100 TR/RD ⁽³⁾	1



⁽¹⁾K-wire supplied separately - Medetechnik® K-wire (33-T10-R-09-080) or Novastep® K-wire (CKW01009) are available depending on your market.

⁽²⁾K-wire supplied separately - Medetechnik® K-wire (33-T10-R-10-080) or Novastep® K-wire (CKW01006) are available depending on your market.

⁽³⁾K-wire supplied separately - Medetechnik® K-wire (33-T10-R-14-100) or Novastep® K-wire (CKW01002) are available depending on your market.

**Optional

Nexis® module Ø 2, 2.3 & 2.9

Number	Ref	Description	Qty
	ACC1001P0006	Module	1
1	XSD01001	T7 AO screwdriver tip	1
2	XSD02001	T8 AO screwdriver tip	1
3	XSD03001	Snap-off AO screwdriver tip	1
4	XRE01001	Countersink Ø 2.75	1
5	XDB02001	Solid drill bit Ø 1.75	1
6	XDB01001	Cannulated drill bit Ø 1.75	1



nexis[®]

Cannulated Screws

Please note:

Carefully read the enclosed Instructions For Use (IFU) and all packaging label information. Devices: Implants: Class IIb-CE1639 / Instruments: Class I / Class Ir-CE1639 / Class IIa-CE1639.

Novastep:

2, Allée Jacques Frimot - 35000 RENNES - France
Tel. : + 33 (0) 2 99 33 86 50 / Fax : + 33 (0) 9 70 29 18 95
contact@novastep-ortho.com / www.int.novastep.life

Reference: Nex-FORE-ST-Ed2-07-24-EN